

RECOMMENDED PCB LAYOUT

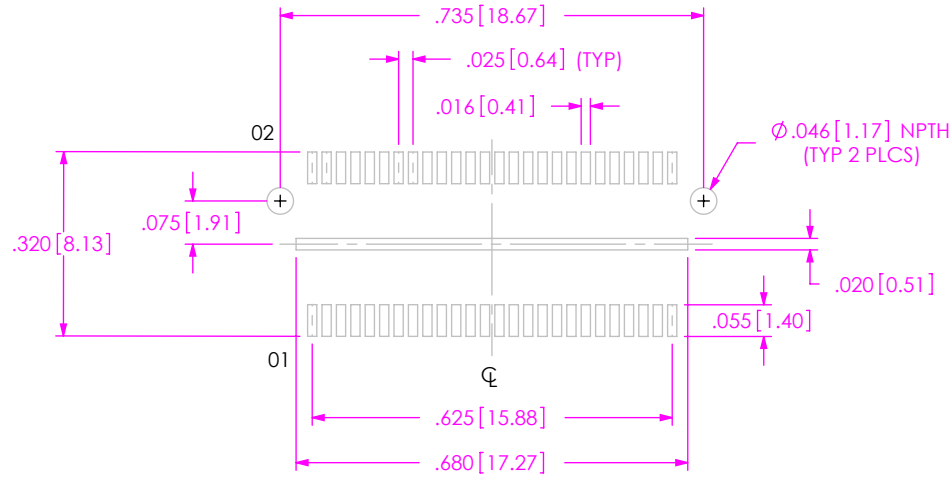

(ALL DIMENSIONS ARE SYMMETRIC ABOUT THE CENTERLINE)

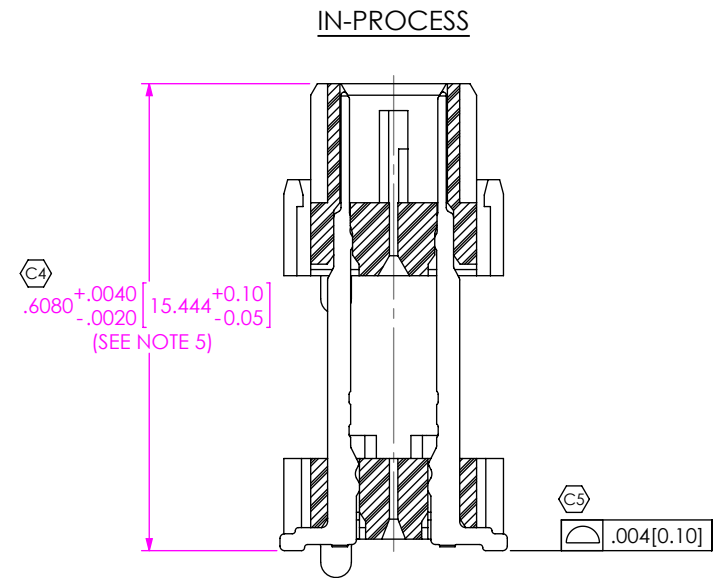
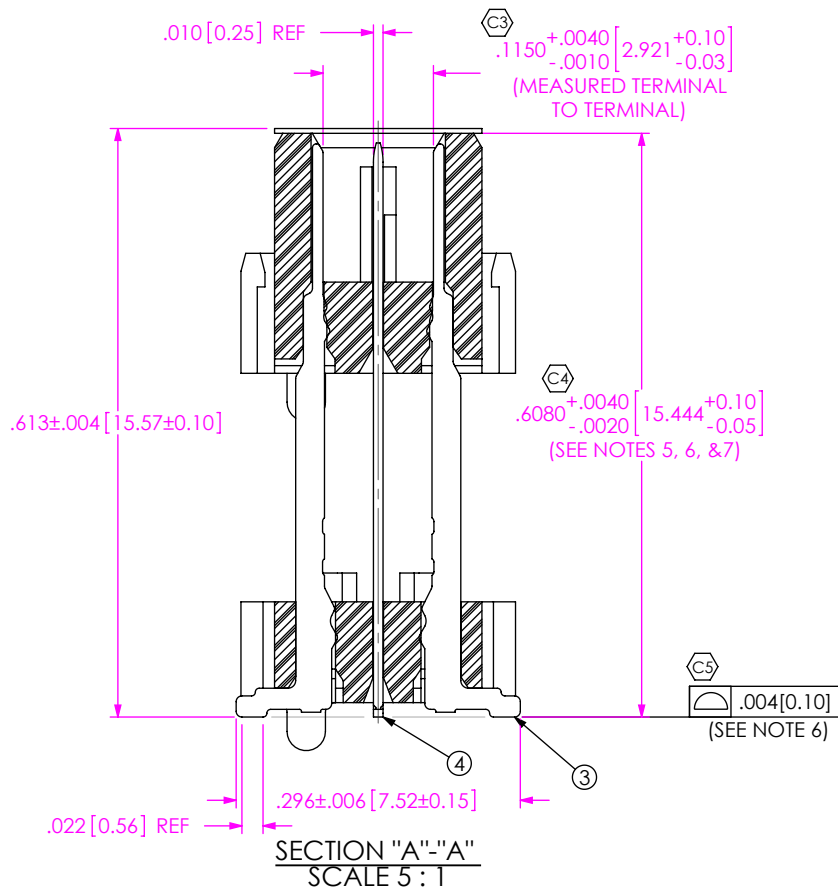

PROPRIETARY NOTE

THIS DOCUMENT CONTAINS INFORMATION CONFIDENTIAL AND PROPRIETARY TO SAMTEC, INC. AND SHALL NOT BE REPRODUCED OR TRANSFERRED TO OTHER DOCUMENTS OR DISCLOSED TO OTHERS OR USED FOR ANY PURPOSE OTHER THAN THAT WHICH IT WAS OBTAINED WITHOUT THE EXPRESSED WRITTEN CONSENT OF SAMTEC, INC.

SHEET SCALE: 2.5:1



520 PARK EAST BLVD, NEW ALBANY, IN 47150
 PHONE: 812-944-6733 FAX: 812-948-5047
 e-Mail: info@SAMTEC.com code: 55322

DESCRIPTION:
 ELEVATED QMS ASSM (22MM STACK)

DWG. NO.
 ASP-142781-01

BY: C. RYAN 10/17/2008 SHEET 2 OF 3

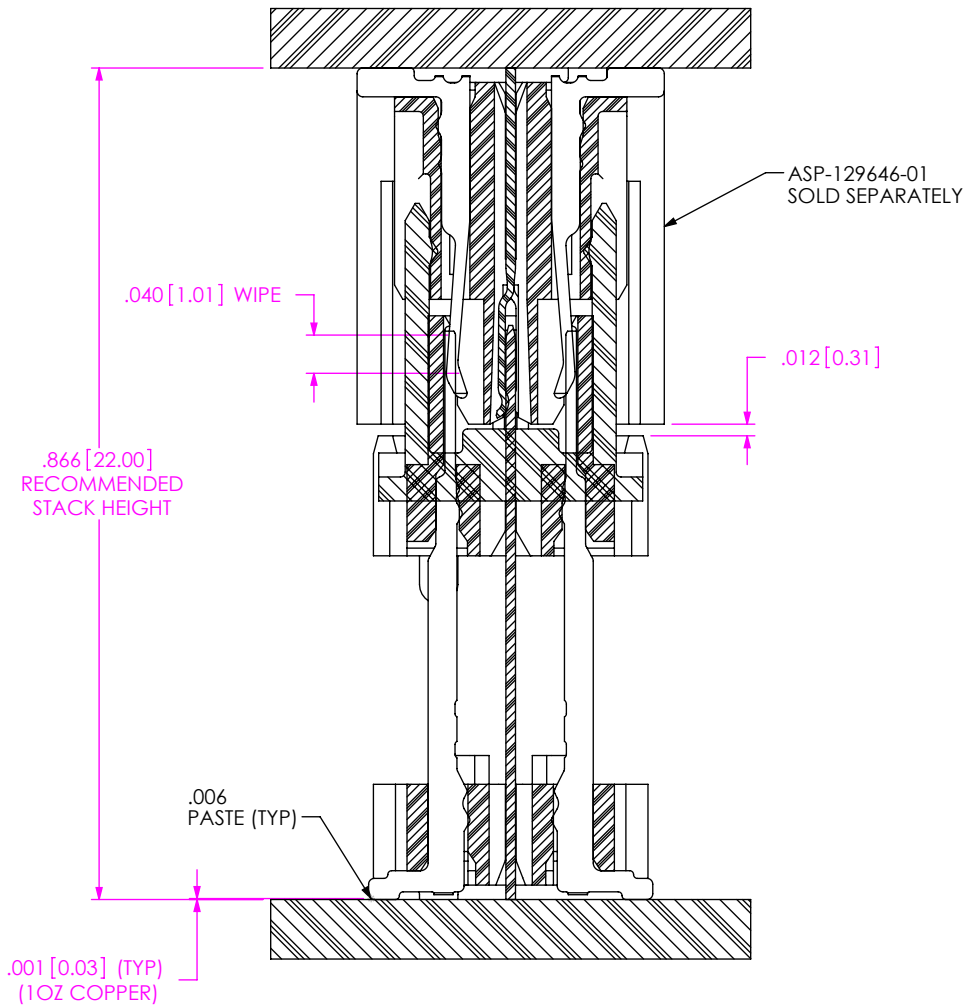

MATED VIEW
USE STANDOFF SO-2200-03-01-02-L-N WHEN MATING

A PACKAGING VIEW
(SEE NOTE 9)

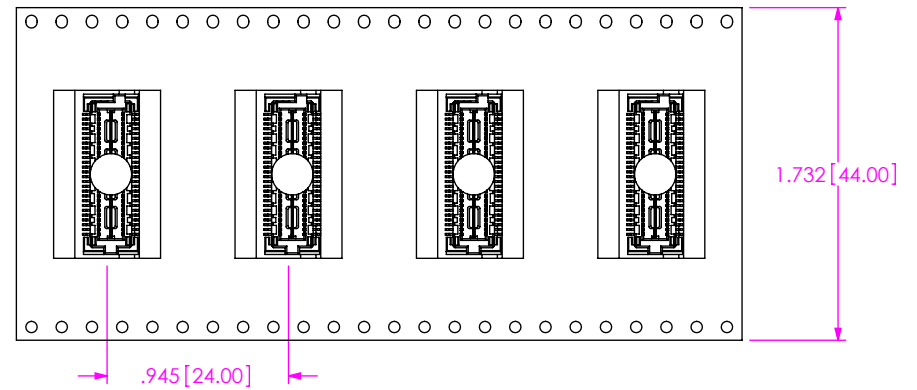

USER DIRECTION OF UN-REELING
POCKET NOT DETAILED

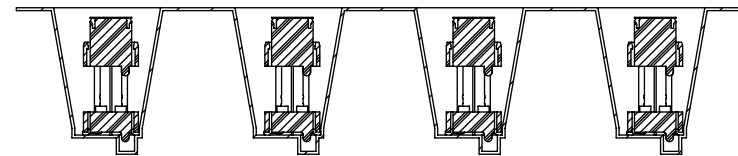

PROPRIETARY NOTE

THIS DOCUMENT CONTAINS INFORMATION
CONFIDENTIAL AND PROPRIETARY TO
SAMTEC, INC. AND SHALL NOT BE REPRODUCED
OR TRANSFERRED TO OTHER DOCUMENTS OR
DISCLOSED TO OTHERS OR USED FOR ANY
PURPOSE OTHER THAN THAT WHICH IT WAS
OBTAINED WITHOUT THE EXPRESSED WRITTEN
CONSENT OF SAMTEC, INC.

SHEET SCALE: 2.5:1



520 PARK EAST BLVD, NEW ALBANY, IN 47150
PHONE: 812-944-6733 FAX: 812-948-5047
e-Mail: info@SAMTEC.com code: 55322

DESCRIPTION:
ELEVATED QMS ASSM (22MM STACK)

DWG. NO.
ASP-142781-01

BY: C. RYAN 10/17/2008 SHEET 3 OF 3