



# Application Note

## **PCIEC Series Extender Cable Assembly 1 Meter Assembly Length Final Inch™ Designs In PCI Express Applications Generation 2 – 5.0 Gbps**

Revision Date: February 13, 2009

**Copyrights and Trademarks**  
Copyright © 2009 Samtec, Inc.

Developed in conjunction with  
Teraspeed Consulting Group LLC

---

**Series:** PCIeC Extender Cable Assembly, 1 Meter Assembly Length  
**Standard:** PCI Express, Generation 2

## COPYRIGHTS, TRADEMARKS, and PATENTS

Eye Speed™ and Final Inch® are trademarks of Samtec, Inc. Other product names used herein are trademarks of their respective owners. All information and material in this publication are property of Samtec, Inc. All related rights are reserved. Samtec, Inc. does not authorize customers to make copies of the content for any use.

### ***Terms of Use***

Use of this publication is limited to viewing the pages for evaluation or purchase. No permission is granted to the user to copy, print, distribute, transmit, display in public, or modify the contents of this document in any way.

### ***Disclaimer***

The information in this publication may change without notice. All materials published here are “As Is” and without implied or expressed warranties. Samtec, Inc. does not warrant this publication will be without error, or that defects will be corrected. Samtec, Inc. makes every effort to present our customers an excellent and useful publication, but we do not warrant or represent the use of the materials here in terms of their accuracy, reliability or otherwise. Therefore, you agree that all access and use of this publication's content is at your own risk.

NEITHER SAMTEC, INC. NOR ANY PARTY INVOLVED IN CREATING, PRODUCING, OR DELIVERING THIS PUBLICATION SHALL BE LIABLE FOR ANY DIRECT, INCIDENTAL, CONSEQUENTIAL, INDIRECT, OR PUNITIVE DAMAGES ARISING OUT OF YOUR ACCESS, USE OR INABILITY TO ACCESS OR USE THIS PUBLICATION, OR ANY ERRORS OR OMISSIONS IN ITS CONTENT.

---

**Series:** PCIEC Extender Cable Assembly, 1 Meter Assembly Length  
**Standard:** PCI Express, Generation 2

## **Abstract**

The PCI Express is primarily intended as a high performance serial interface targeted for use in desktop, mobile, workstation, server, communications platforms, and embedded devices. As with any modern high speed PCB design, the performance of an actual PCI Express Generation 2 interconnect is signal integrity is highly dependent on the implementation. This paper describes a measurement method applied to proven Samtec Final Inch® designs and this industry standard to help engineers deploy of the PCIEC Data Rate jumper assembly between two PCB cards. To demonstrate the feasibility of using standard PCIe through-hole connectors and the PCIe cable jumper assembly with standard FR4 epoxy PCBs, informative interconnect loss and jitter values will be measured through Spice simulation and presented in spreadsheet format. Also, trace lengths on the test PCBs will be gradually increased to show the limits of compliance.

This will simulate the stress a typical driver-trace-BOR-connector-cable-connector-BOR-trace-receiver interconnect design by stimulating the equivalent Spice model components and devices with worst case data patterns as described in Section 4.3.6.2.4 of PCI Express Base Specification, Rev 2.0. This paper will cover techniques to stress the system with reduced driver amplitude as well as max transmit jitter and noise injection.

---

**Series:** PCIEC Extender Cable Assembly, 1 Meter Assembly Length  
**Standard:** PCI Express, Generation 2

## Introduction

Samtec has developed a full line of connector products that are designed to support serial speeds greater than 5.0 Gbps, the “Baud rate” of each PCI Express Generation 2 data lane. Working with Teraspeed Consulting, they have developed a complete breakout and routing solution for each member of Samtec’s line of high speed connectors, called Final Inch®. To demonstrate the feasibility of using Samtec PCIEC cables in PCI Express applications with standard FR4 epoxy PCBs, informative interconnect loss and jitter values will be measured through Spice simulation and presented in a user-friendly spreadsheet format. Trace lengths will be varied to show the limits of compliance.

Analysis will consist of stimulating a typical trace-connector-trace circuit path with a worst case signal and then observing the corresponding eye closure related to reflections due to impedance discontinuities, loss, and stubs. Next, utility software will be used to extract, analyze, and format Spice-measured voltage amplitudes and differential signal crossing times. Mask violations (see Figure 2) will be recorded in pass/fail format.

## Definitions

**Interconnect Budget** – The amount of loss and jitter that is allowed in the interconnect and still meet the target specification.

**Loss** – The differential voltage swing attenuation from transmitter to receiver on the trace. The trace is subject to resistive, dielectric, and skin effect loss. Loss increases as trace length and and/or signal frequency increases. Vias and connectors also exhibit losses which must be included in the interconnect budget. Total loss allowed in the interconnect is 13.2 dB.

**Jitter** – The variation in the time between differential crossings from the ideal crossing time. Jitter includes both data dependent and random contributions on the interconnect. Total jitter allowed is  $0.4UI$ , or 80 ps when  $UI = 200$  ps.

**PRBS** – Pseudo Random Bit Sequence.

**T<sub>j</sub>** – Total jitter, which is the convolution of the probability density functions for all the jitter sources, Random jitter (R<sub>j</sub>) and Deterministic jitter (D<sub>j</sub>). The UI allocation is given as the allowable T<sub>j</sub>. The PCI Express specification does not specify allocation of R<sub>j</sub> and D<sub>j</sub>.

**UI** – Unit Interval. The time interval required for transmission of one data symbol. For a binary lane operating at 5.0 Gbps, the UI is 200 ps.

**Series:** PCIeC Extender Cable Assembly, 1 Meter Assembly Length

**Standard:** PCI Express, Generation 2

$V_{DIFF}$  – Differential voltage, defined as the difference of the positive conductor voltage and the negative conductor voltage ( $V_{D+} - V_{D-}$ ).

$V_{DIFFp-p}$  – Differential peak-to-peak voltage, defined by the following equations:

$$V_{DIFFp-p} = (2 * \max | V_{D+} - V_{D-} |) \text{ (Applies to a symmetric differential swing)}$$

$$V_{DIFFp-p} = (\max | V_{D+} - V_{D-} | \{ V_{D+} > V_{D-} \} + \max | V_{D+} - V_{D-} | \{ V_{D+} < V_{D-} \})$$

(Applies to a asymmetric differential swing)

## The PCI Express Specification

PCI Express links are based on recent advances in point-to-point interconnect technology. A PCI Express link is comprised of a dual-simplex communications channel between two components physically consisting of two low-voltage, differential signal pairs. The PCI Express Base Specification defines one half of a link (one transmitter and receiver) an electrical sub-block. The design model used for this paper is of three electrical sub-blocks operating in tandem, the victim surrounded by multiple aggressors, with all bit streams heading in the same direction.

Detailed specifications for an electrical sub-block can be found in the PCI Express 2.0 Base Specification and will be referred to throughout the rest of this paper<sup>1</sup>. Measurement techniques specified in this section have been rigidly adhered to including the requirement for finding the median within the jitter for use in jitter measurements.

---

<sup>1</sup> The PCI Express Base 2.0 specification is available for purchase through the PCI Sig organization ([http://www.pcisig.com/specifications/ordering\\_information](http://www.pcisig.com/specifications/ordering_information)).

---

**Series:** PCIEC Extender Cable Assembly, 1 Meter Assembly Length  
**Standard:** PCI Express, Generation 2

## Setup and Measurement

### *Input Stimulus Setup*

A PRBS  $2^7-1$  pattern was used for victim stimulus pair and a repeating 1010... pattern used for the aggressor pairs surrounding the victim pair. Teraspeed has developed its own stimulus conversion tool that has the capability to selectively de-emphasize and/or add jitter to the HSICE stimulus output, such as a vector file. This was used to add enough jitter and de-emphasis to just meet worst case PCI Express Generation 2 transmit jitter specifications.

### *The Test Circuit Model*

The test circuit modeled is shown in Figure 1. It consists of the following:

- One set of Teraspeed behavioral driver models with programmable edge rate, amplitude, and de-emphasis.
- One set of six DC blocking capacitors, value = 100 nF
- 2 PCI Express Final Inch™ test PCB SPICE deck, comprised of the PCIe connector model surrounded by the Samtec's BOR models, lossy trace models (5mil; stripline; FR\$), and SMA connector models.
- 1 PCIEC Extender Cable Assembly SPICE model.
- 50 Ohm termination resistors to Ground (as required per Note 7 in Section 4.3.4 of the PCI Express Base Specification, Rev 1.0a.

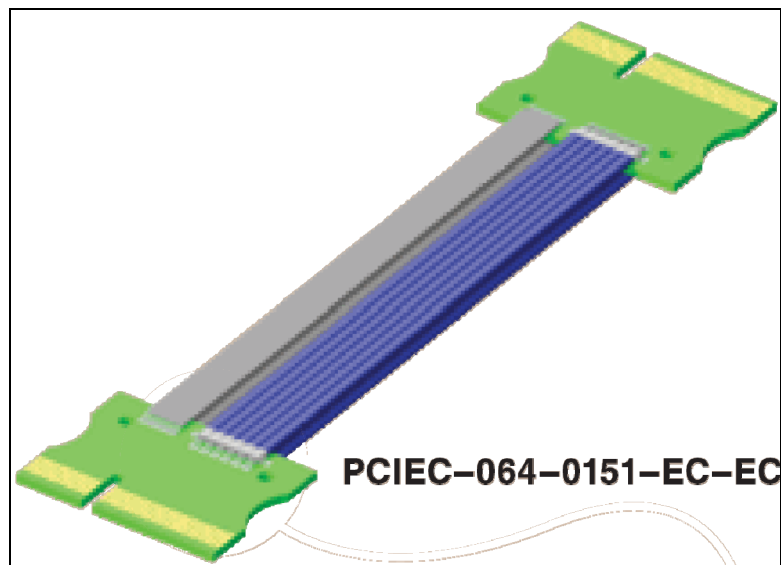
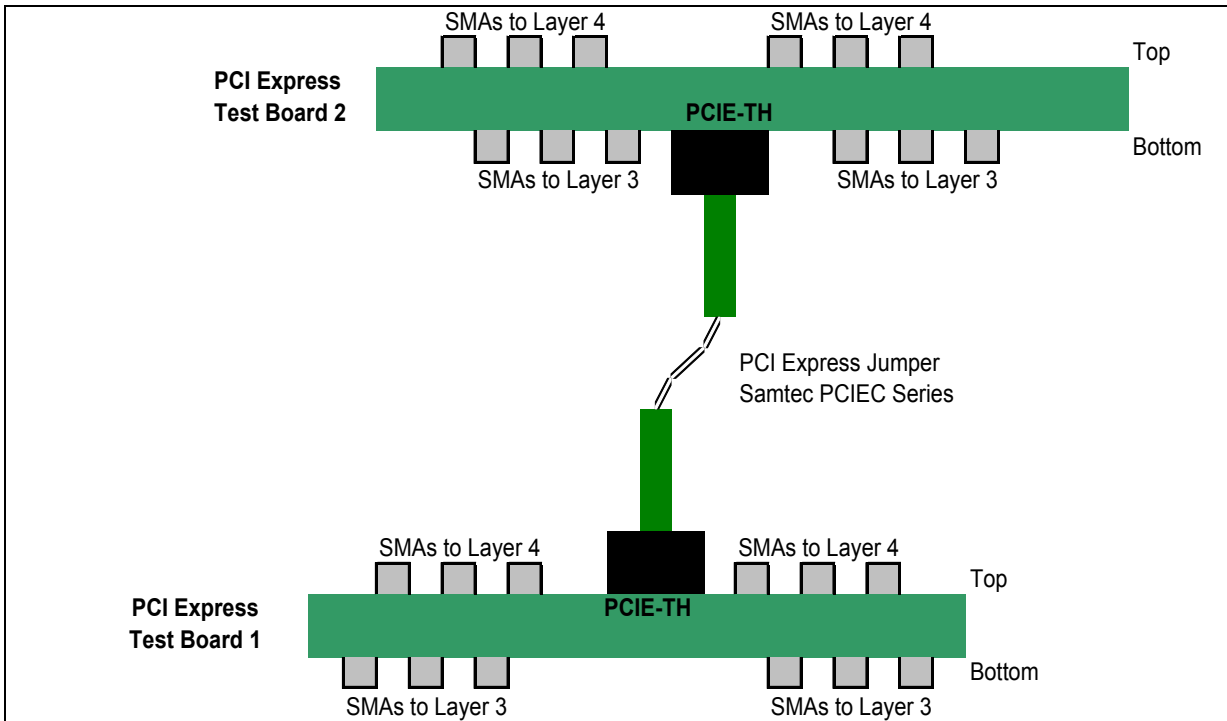
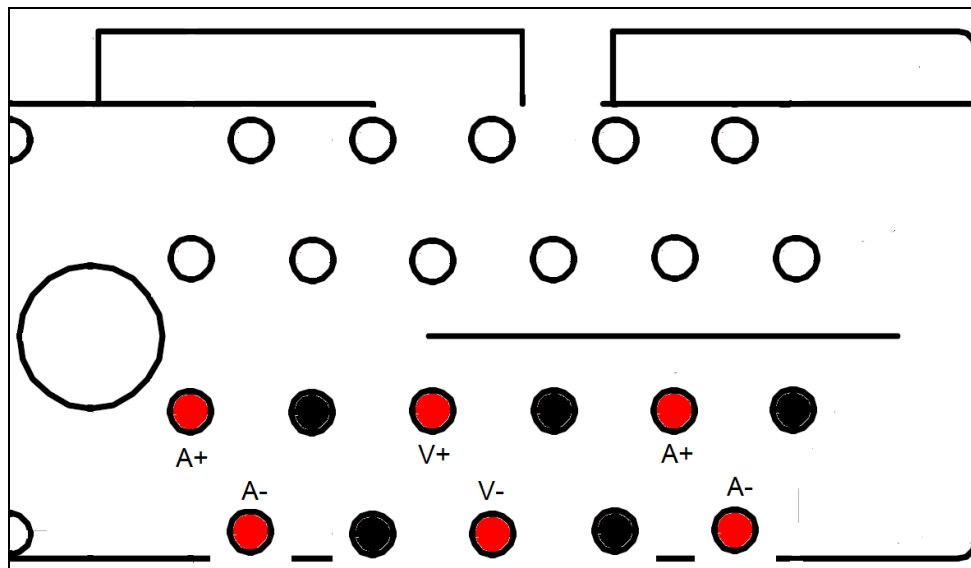

Figure 1 - Samtec PCIEC Series Data Rate Cable Jumper. Simulated cable length = 1 meter.

**Series:** PCIEC Extender Cable Assembly, 1 Meter Assembly Length  
**Standard:** PCI Express, Generation 2



**Figure 2 - PCI Express Cable Test Circuit; includes Final Inch connector breakout pattern on each test PCB.**



**Figure 3 – PCIe Through-hole connector test case signal pin patterns for HSPICE simulations. V = Victim, A = Aggressor. Black = grounded connections.**



**Series:** PCIeC Extender Cable Assembly, 1 Meter Assembly Length  
**Standard:** PCI Express, Generation 2

	Low Power Differential Maximum Loss, A1 to -A1 (See example mask template) ( $V_{DIFFp-p}$ )	Normal Power Differential Maximum Loss, A1 to -A1 (See example mask template) ( $V_{DIFFp-p}$ )	Minimum Eye Width, X1 to 1-X1 (See example mask template) ( $UI_{p-p}$ )
Driver at Package Pin	0.400	0.800	0.75
Receiver at Package Pin	0.120	0.120	0.60 <sup>2</sup>
Interconnect budget:	10.5 dB loss	16.5 dB loss <sup>1</sup>	0.15 UI (30ps when UI = 200 ps)

**Table 1 - PCI Express Gen 2 interconnect budgets: max loss and min eye width calculated values**

<sup>1</sup>The worst case operational loss budget at 2.5 GHz Nyquist frequency is calculated by taking the minimum driver output voltage ( $V_{TX-DIFFp-p} = 800$  mV) divided by the minimum input voltage to the receiver ( $V_{RX-DIFFp-p} = 175$  mV).  $175/800 = .219$ , which after conversion results in a maximum loss budget of 13.2 dB.

<sup>2</sup>Minimum width pulse at Rx after accounting for worst Tj at  $10^{-12}$  BER. See Table 4-12 in the PCI Express Base Specification, Revision 2.0.

## Transmitter Compliance Measurements

### Setup for Tj for UI Measurements

Before the PCI Express circuit model can be simulated and measured, we must first set up the driver stimulus to provide minimum TX eye width (maximum jitter) and minimum amplitude for both low power and regular power driver models. As mentioned in the previous section, the driver stimulus' jitter can be adjusted until it just reaches the maximum total jitter allowed under the compliance load shown in the figure below. The AC coupling capacitor  $C_{TX}$  can be set anywhere between 75pF and 200pF. We set  $C_{TX}$  to 100nF for all simulations because it is a popular value in the industry. Table 2 shows the resulting output measurements. The eye pattern generated in the PCI Express driver compliance test simulation can be found in [Appendix A](#), Picture 1, of this paper.

**Series:** PCIeC Extender Cable Assembly, 1 Meter Assembly Length  
**Standard:** PCI Express, Generation 2

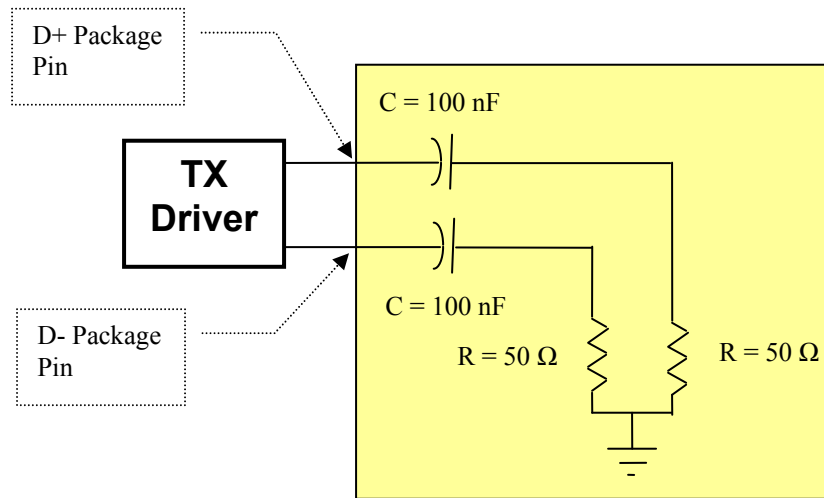

Figure 5 - PCI Express Compliance Test/Measurement load

De-emphasis		Vdiff <sub>p-p</sub>		Total Jitter	Edge Rate
		Transition Bit	De-emphasized Bit	≤0.25 UI, measured at crossings	≥0.15 UI, measured 20% to 80%
0dB (Low Power)	<b>Specification</b>	≥400 mV	None	≤50 ps	≥30ps
	<b>Measured</b>	401 mV <sup>1</sup>	-	46 ps	34ps
-3 dB	<b>Specification</b>	≥800 mV	≥566 mV	≤50 ps	≥30ps
	<b>Measured</b>	800 mV <sup>1</sup>	566 mV	49 ps	30ps
-4 dB	<b>Specification</b>	≥800 mV	≤505 mV	≤50 ps	≥30ps
	<b>Measured</b>	800 mV <sup>1</sup>	505 mV	49 ps	30ps
-5.5 dB	<b>Specification</b>	≥800 mV	≥425 mV	≤50 ps	≥30ps
	<b>Measured</b>	800 mV <sup>1</sup>	425 mV	49 ps	30ps
-6.5 dB	<b>Specification</b>	≥800 mV	≤378 mV	≤50 ps	≥30ps
	<b>Measured</b>	800 mV <sup>1</sup>	378 mV	49 ps	30 ps

Table 2- PCI Express TX Silicon + Package Measurements at Package Pin

<sup>1</sup>The PCI Express Base Specification defines X2 to 1-X2 = 0. The minimum TX height measurements were taken at mid bit.

**Series:** PCIEC Extender Cable Assembly, 1 Meter Assembly Length  
**Standard:** PCI Express, Generation 2

**Measurements at the Receiver**

Notes:

- 1.) The total trace length specified is the sum of the test cards’ differential traces as shown in Figure 2. Both trace lengths are equal in each simulation.
- 2.) For each of the following tables, the eye patterns generated in the PCI Express circuit simulation with the maximum allowable total trace length in each of the following table can be found in [Appendix A](#) of this paper.

Mated PCIEC 1meter Final Inch Circuit	Min RX Differential Voltage, A1 to -A1 <sup>1</sup> (See example mask template)	Min RX Eye Width, X1 to 1-X1 (See example mask template)	Pass/Fail
<b>Specification</b>	<b>≥120 mV<sub>DIFFp-p</sub></b>	<b>≥120 ps</b>	-
5.0" total trace	150 mV	130 ps	Pass
6.0" total trace	140 mV	130 ps	Pass
7.0" total trace	133 mV	129 ps	Pass
8.0" total trace	126 mV	126 ps	Pass
9.0" total trace	118 mV	123 ps	Fail

Table 3 - PCI Express Cable Far-end Measurements, Low Power Driver.

Mated PCIEC 1meter Final Inch Circuit	Min RX Differential Voltage, A1 to -A1 <sup>1</sup> (See example mask template)	Min RX Eye Width, X1 to 1-X1 (See example mask template)	Pass/Fail
<b>Specification</b>	<b>≥120 mV<sub>DIFFp-p</sub></b>	<b>≥120 ps</b>	-
5.0" total trace	286 mV	147 ps	Pass
10.0" total trace	229 mV	143 ps	Pass
15.0" total trace	179 mV	136 ps	Pass
20.0" total trace	140 mV	125 ps	Pass
21.0" total trace	132 mV	123 ps	Pass
22.0" total trace	127 mV	120 ps	Pass
23.0" total trace	120 mV	118 ps	Fail

Table 4 - PCI Express Connector Far-end Measurements, Normal Driver with -3dB de-emphasis.

**Series:** PCIeC Extender Cable Assembly, 1 Meter Assembly Length  
**Standard:** PCI Express, Generation 2

Mated PCIeC 1meter Final Inch Circuit	Min RX Differential Voltage, A1 to -A1 <sup>1</sup> (See example mask template)	Min RX Eye Width, X1 to 1-X1 (See example mask template)	Pass/Fail
<b>Specification</b>	<b>≥120 mV<sub>DIFFp-p</sub></b>	<b>≥120 ps</b>	-
5.0" total trace	265 mV	146 ps	Pass
10.0" total trace	240 mV	145 ps	Pass
15.0" total trace	191 mV	142ps	Pass
20.0" total trace	152 mV	135 ps	Pass
22.0" total trace	141 mV	130 ps	Pass
24.0" total trace	129 mV	127 ps	Pass
25.0" total trace	124 mV	125 ps	Pass
26.0" total trace	116 mV	122 ps	Fail

Table 5 - PCI Express Connector Far-end Measurements, Normal Driver with -4dB de-emphasis.

Mated PCIeC 1meter Final Inch Circuit	Min RX Differential Voltage, A1 to -A1 <sup>1</sup> (See example mask template)	Min RX Eye Width, X1 to 1-X1 (See example mask template)	Pass/Fail
<b>Specification</b>	<b>≥120 mV<sub>DIFFp-p</sub></b>	<b>≥120 ps</b>	-
5.0" total trace	228 mV	142 ps	Pass
10.0" total trace	218 mV	143 ps	Pass
15.0" total trace	200 mV	143 ps	Pass
20.0" total trace	170 mV	142 ps	Pass
24.0" total trace	146 mV	139 ps	Pass
28.0" total trace	125 mV	135 ps	Pass
29.0" total trace	121 mV	132 ps	Pass
30.0" total trace	114 mV	129 ps	Fail

Table 6 - PCI Express Connector Far-end Measurements, Normal Driver with -5.5dB de-emphasis.

**Series:** PCIeC Extender Cable Assembly, 1 Meter Assembly Length  
**Standard:** PCI Express, Generation 2

Mated PCIeC 1meter Final Inch Circuit	Min RX Differential Voltage, A1 to -A1 <sup>1</sup> (See example mask template)	Min RX Eye Width, X1 to 1-X1 (See example mask template)	Pass/Fail
<b>Specification</b>	<b>≥120 mV<sub>DIFFp-p</sub></b>	<b>≥120 ps</b>	-
5.0" total trace	205 mV	137 ps	Pass
10.0" total trace	200 mV	138 ps	Pass
15.0" total trace	188 mV	139 ps	Pass
20.0" total trace	175 mV	140 ps	Pass
25.0" total trace	151 mV	140 ps	Pass
30.0" total trace	126 mV	137 ps	Pass
31.0" total trace	121 mV	136 ps	Pass
32.0" total trace	116 mV	135 ps	Fail

Table 7 - PCI Express Connector Far-end Measurements, Normal Driver with -6.5dB de-emphasis.

## Conclusions

When used with Samtec’s Final Inch® differential routing, breakout, and trace width solution, a 1 meter long PCIeC series extender cable assembly can be used to transfer PCI Express lanes with total trace lengths up to:

- 8 inches in low power driver mode.
- 22 inches when using a normal driver with -3 dB de-emphasis.
- 25 inches when using a normal driver with -4 dB de-emphasis.
- 29 inches when using a normal driver with -5.5 dB de-emphasis.
- 31 inches when using a normal driver with -6.5 dB de-emphasis

## Recommendations

Designers should be aware that using smaller trace widths, laminates with higher loss tangent, and sub optimal routing solutions with higher pair-to-pair coupling and additional via stubs will decrease overall performance and the maximum allowable trace length. It is advisable, when designing systems that approach the maximum trace length limits, to perform detailed modeling, simulation, and measurement of the target design including the effects of material properties, traces, vias, and additional components

Series: PCIeC Extender Cable Assembly, 1 Meter Assembly Length  
 Standard: PCI Express, Generation 2

## Appendix A – Waveform images

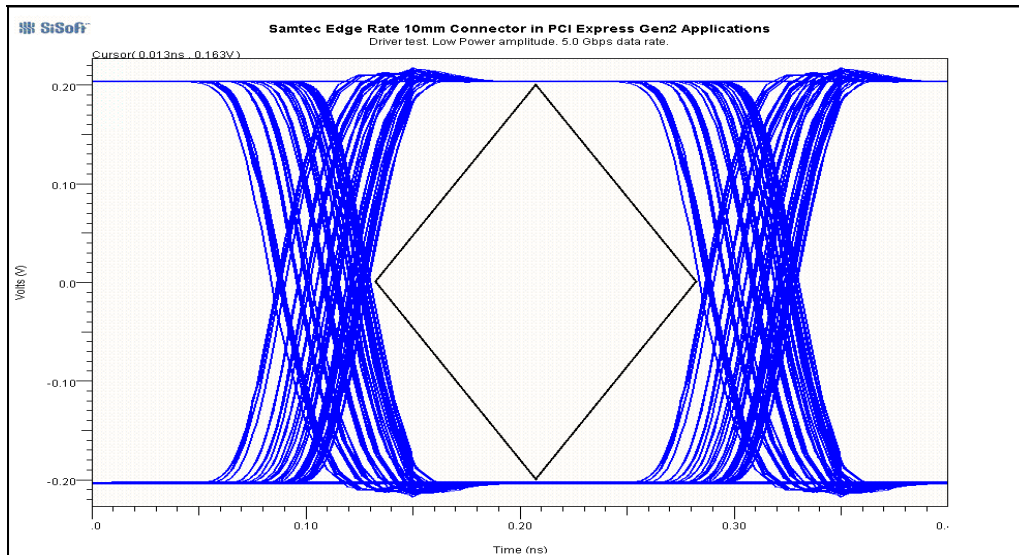

Picture 1 – Example of worst case stimulus eye waveform, probed at Teraspeed driver behavioral model nodes connected to PCIe compliance test/measurement load. Low power setting.

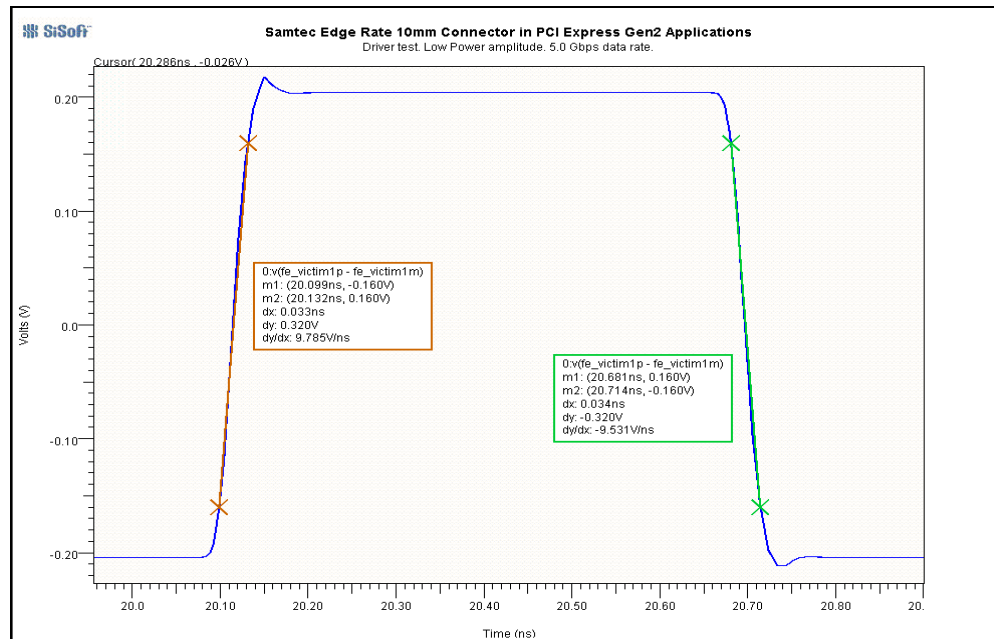

Picture 2 – Example of worst case stimulus measurement, probed at Teraspeed driver behavioral model nodes connected to PCIe compliance test/measurement load. Low power setting.

**Series:** PCIeC Extender Cable Assembly, 1 Meter Assembly Length  
**Standard:** PCI Express, Generation 2

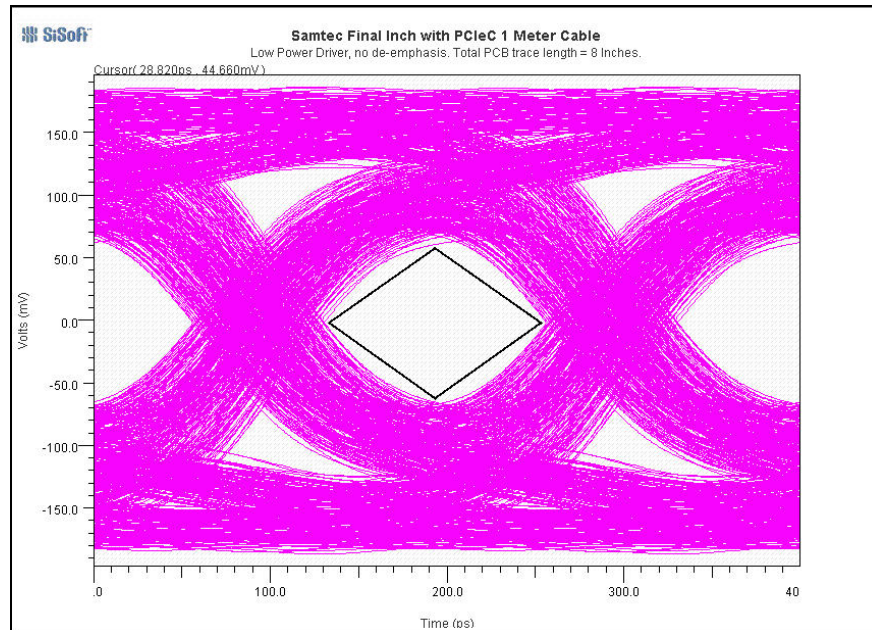

**Picture 3 – Receiver eye measurement, probed at far end termination. Low power driver setting with 0 dB de-emphasis. Total PCB trace length = 8 inches.**

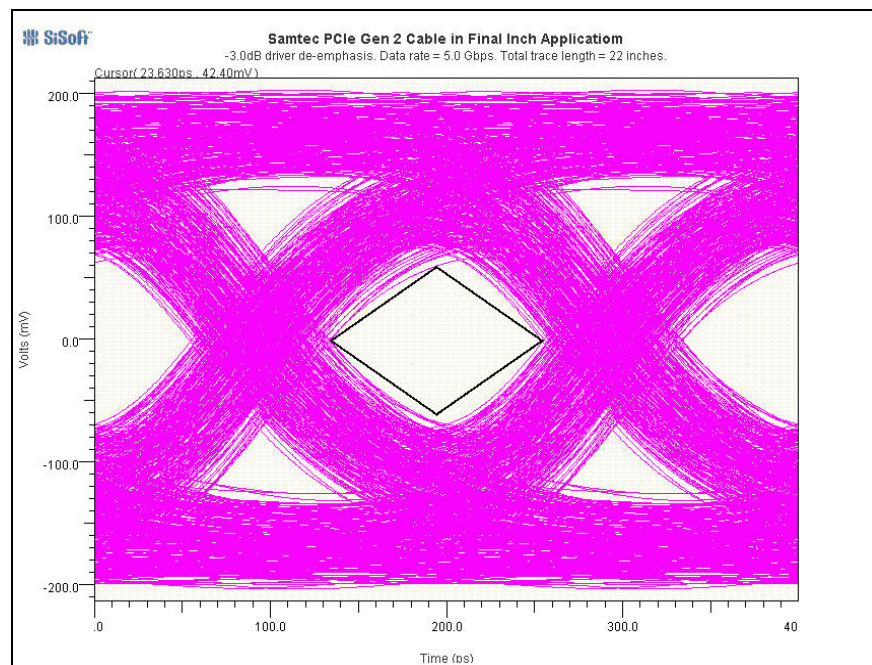

**Picture 4 – Receiver eye measurement, probed at far end termination. Normal power driver setting with -3 dB de-emphasis. Total trace length = 22 inches.**

**Series:** PCIeC Extender Cable Assembly, 1 Meter Assembly Length  
**Standard:** PCI Express, Generation 2

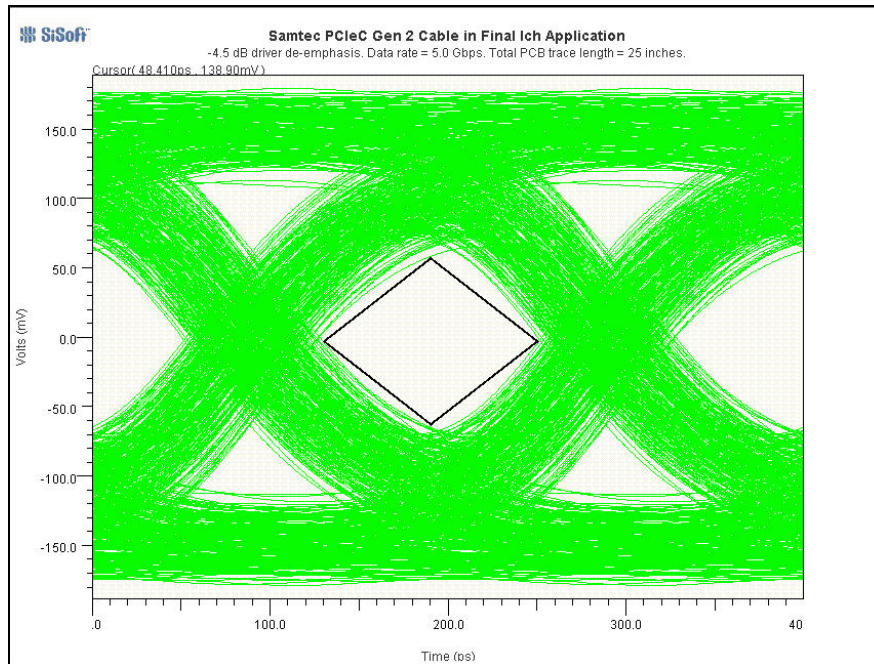

**Picture 5 – Receiver eye measurement, probed at far end termination. Normal power driver setting with -4 dB de-emphasis. Total PCB trace length = 25 inches.**

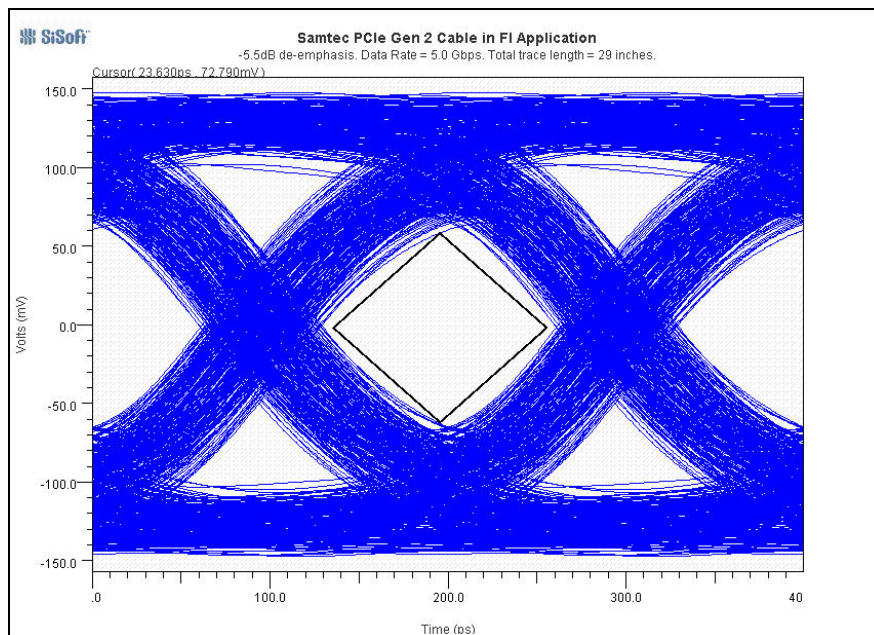

**Picture 6 – Receiver eye measurement, probed at far end termination. Normal power driver setting with -5.5 dB de-emphasis. Total PCB trace length = 29 inches**

**Series:** PCIeC Extender Cable Assembly, 1 Meter Assembly Length  
**Standard:** PCI Express, Generation 2

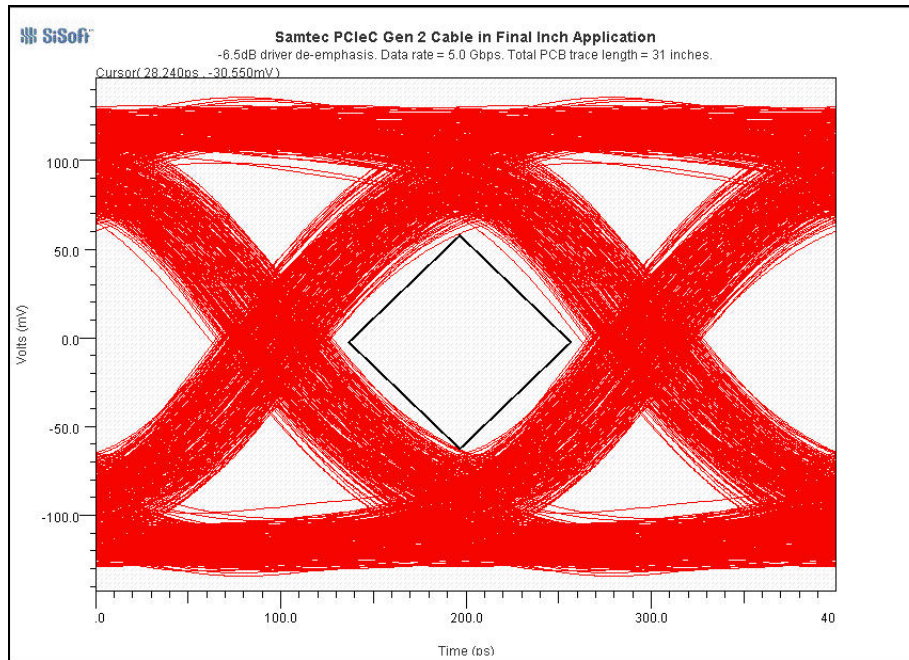

**Picture 7 – Receiver eye measurement, probed at far end termination. Standard driver setting with -6.5 dB de-emphasis. Total trace length = 31 inches.**