



Application Note

SE Array™ SEAM/SEAF Final Inch® Designs in RapidIO Short Run (Mezzanine) Applications 7mm Stack Height

REVISION DATE: January 3, 2005

Copyrights and Trademarks
Copyright © 2005 Samtec, Inc.

Developed in conjunction with
Teraspeed Consulting Group LLC



COPYRIGHTS, TRADEMARKS, and PATENTS

SE Array™ and Final Inch® are trademarks of Samtec, Inc. Other product names used herein are trademarks of their respective owners. All information and material in this publication are property of Samtec, Inc. All related rights are reserved. Samtec, Inc. does not authorize customers to make copies of the content for any use.

Terms of Use

Use of this publication is limited to viewing the pages for evaluation or purchase. No permission is granted to the user to copy, print, distribute, transmit, display in public, or modify the contents of this document in any way.

Disclaimer

The information in this publication may change without notice. All materials published here are "As Is" and without implied or expressed warranties. Samtec, Inc. does not warrant this publication will be without error, or that defects will be corrected. Samtec, Inc. makes every effort to present our customers an excellent and useful publication, but we do not warrant or represent the use of the materials here in terms of their accuracy, reliability or otherwise. Therefore, you agree that all access and use of this publication's content is at your own risk.

NEITHER SAMTEC, INC. NOR ANY PARTY INVOLVED IN CREATING, PRODUCING, OR DELIVERING THIS PUBLICATION SHALL BE LIABLE FOR ANY DIRECT, INCIDENTAL, CONSEQUENTIAL, INDIRECT, OR PUNITIVE DAMAGES ARISING OUT OF YOUR ACCESS, USE OR INABILITY TO ACCESS OR USE THIS PUBLICATION, OR ANY ERRORS OR OMISSIONS IN ITS CONTENT.



Abstract

RapidIO links are based on recent advances in point-to-point interconnect technology. Designed primarily as a physical link intended as a point-to-point interface between devices, a RapidIO lane is comprised of a dual-simplex communications channel between two components physically consisting of two low-voltage, differential signal pairs. As with any modern high speed PCB design, the performance of an actual RapidIO interconnect is highly dependent on the implementation. This paper describes a measurement method applied to proven Samtec Final Inch® designs and this industry standard to help engineers deploy systems of two PCB cards mated through Samtec's family of high speed electrical connectors, what the RapidIO specification calls "short run" or "short range" transmitter specification. To demonstrate the feasibility of using Samtec SE Array™ SEAM/SEAF Series connectors with standard FR4 epoxy PCBs, informative interconnect loss and jitter values will be measured through Spice simulation and presented in spreadsheet format. Also, trace lengths on each side of the SEAM/SEAF connector will be gradually increased to show the limits of compliance.

In order to ensure interoperability between RapidIO transmitter and receiver devices, we will stress a typical interconnect design by stimulating their Spice model components and devices with stressed data patterns. This paper will cover techniques to stress the system with reduced driver amplitude as well as jitter injection.



Introduction

Samtec has developed a full line of connector products that are designed to support serial speeds up to and greater than 3.125 Gb/ps, the highest “Baud rate” of each RapidIO data lane used in this paper. Working with Teraspeed Consulting, they have developed a complete breakout and routing solution for each member of Samtec’s line of high speed connectors called Final Inch®. To demonstrate the feasibility of using the SEAM/SEAF Series connectors in RapidIO applications with standard FR4 epoxy PCBs, informative interconnect loss and jitter values will be measured through Spice simulation and presented in a user-friendly spreadsheet format. Trace lengths will be varied to show the limits of compliance.

Analysis will consist of stimulating a typical trace-connector-trace circuit path with a worst case signal and then observing the corresponding eye closure related to reflections due to impedance discontinuities, loss, and stubs. Next, utility software will be used to extract, analyze, and format Spice-measured voltage amplitudes and differential signal crossing times. Mask violations (see Figure 3) will be recorded in pass/fail format.

Definitions

Interconnect Budget – The amount of loss and jitter that is allowed in the interconnect and still meet the target specification.

Insertion Loss – The differential voltage swing attenuation from transmitter to receiver on the trace. The trace is subject to resistive, dielectric, and skin effect loss. Insertion loss increases as trace length and and/or signal frequency increases. Vias and connectors also exhibit losses which must be included in the interconnect budget.

Jitter – The variation in the time between differential crossings from the ideal crossing time. Jitter includes both data dependent and random contributions on the interconnect.

PRBS – Pseudo Random Bit Sequence.

T_j – Total jitter, which is the convolution of the probability density functions for all the jitter sources, Random jitter (R_j) and Deterministic jitter (D_j). The UI allocation is given as the allowable T_j.

UI – Unit Interval. The time interval required for transmission of one data symbol. For a binary lane operating at 2.5 Gb/p the UI is 400 ps. For 3.125 Gb/s the UI is 320 ps.

V_{DIFF} – Differential voltage, defined as the difference of the positive conductor voltage and the negative conductor voltage (V_{D+} - V_{D-}).



The RapidIO Specification

RapidIO links are based on recent advances in point-to-point interconnect technology. A RapidIO lane is comprised of a dual-simplex communications channel between two components physically consisting of two low-voltage, differential signal pairs. Four of these lanes are used to convey 32-bit self-clocking data and control, each at a nominal rate of 1.25 GBaud, 2.5 GBaud, or 3.125 GBaud.

The RapidIO specification uses the name “byte stream” to describe one half of a data lane. The design model used for this paper is of six byte streams operating in tandem, one victim surrounded by 5 aggressors, with all bit streams heading in the same direction and passing through the connector on adjacent pin pairs.

Detailed electrical specifications for the electrical sub-block can be found starting in Chapter 8 of the RapidIO specification, available free of charge on their web site (www.rapidio.org/specs). Relevant timing and voltage constraints from this section of the specification will be referred to throughout the rest of this paper.

Setup and Measurement

Input Stimulus Setup

A PRBS 2^7-1 pattern was used for victim stimulus and a repeating 1010... pattern used for the aggressor differential pairs on each side of the victim differential pair. Xilinx supplies a stimulus generator tool kit within their VirtexII Pro™ design kit giving customers complete control over the amount of jitter in the transmitter’s data output. Using their stimulus system with their RocketIO™ multi-gigabit serial transceiver model, enough total jitter was added to the driver output to just meet worst case RapidIO transmit jitter specifications. The slow-slow corner silicon model was used to come as close as possible to the minimum differential V_{DIFF} output specification. An adjustable attenuator was then used to match the RapidIO TX $V_{diff,p-p}(min)$ specification.

The Test Circuit Model

The test circuit modeled is shown in Figure 1. It consists of the following:

- One set of six of Xilinx Virtex-II Pro™ serial differential transceiver models configured as RapidIO drivers.
- Xilinx FPGA flip-chip package model
- 1 Samtec SE Array™ Final Inch® design comprised of SEAM-xx-01-H-xx-1 and SEAF-xx-01-H-xx-1 7mm stack height connector models surrounded by the Samtec’s Break Out Routing (BOR) models, lossy trace models, and SMA connector models on both sides of the connector.
- One set of 12 AC coupling capacitors, value = 100 nF.
- One set of six 100 Ohm termination resistors.

Contact Samtec for more details on the SE Array™ SEAM/SEAF Series connectors.

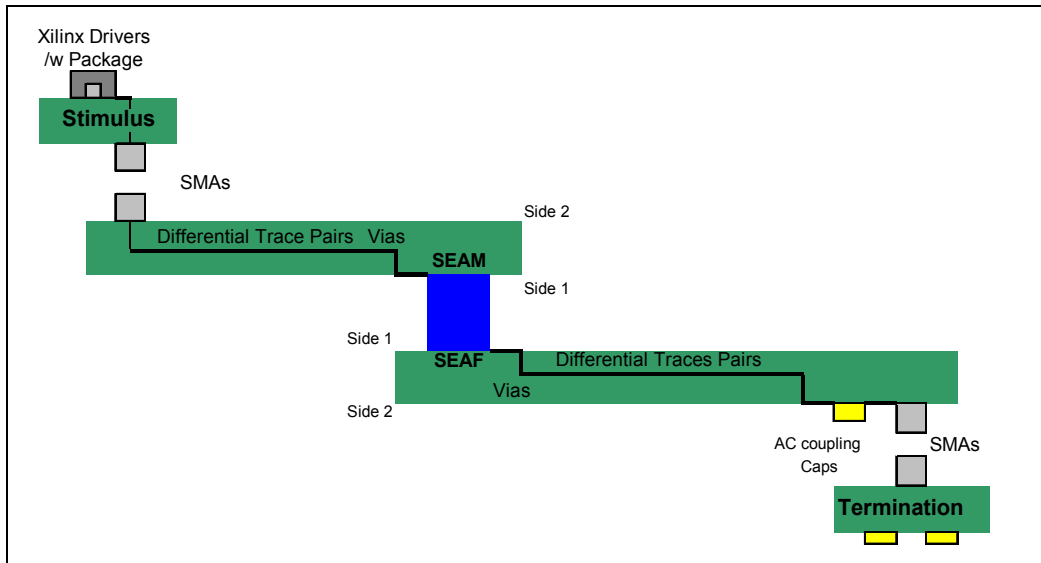

Figure 1 - RapidIO Test Circuit

The SE Array™ connector model signal mapping is shown in Figure 2.

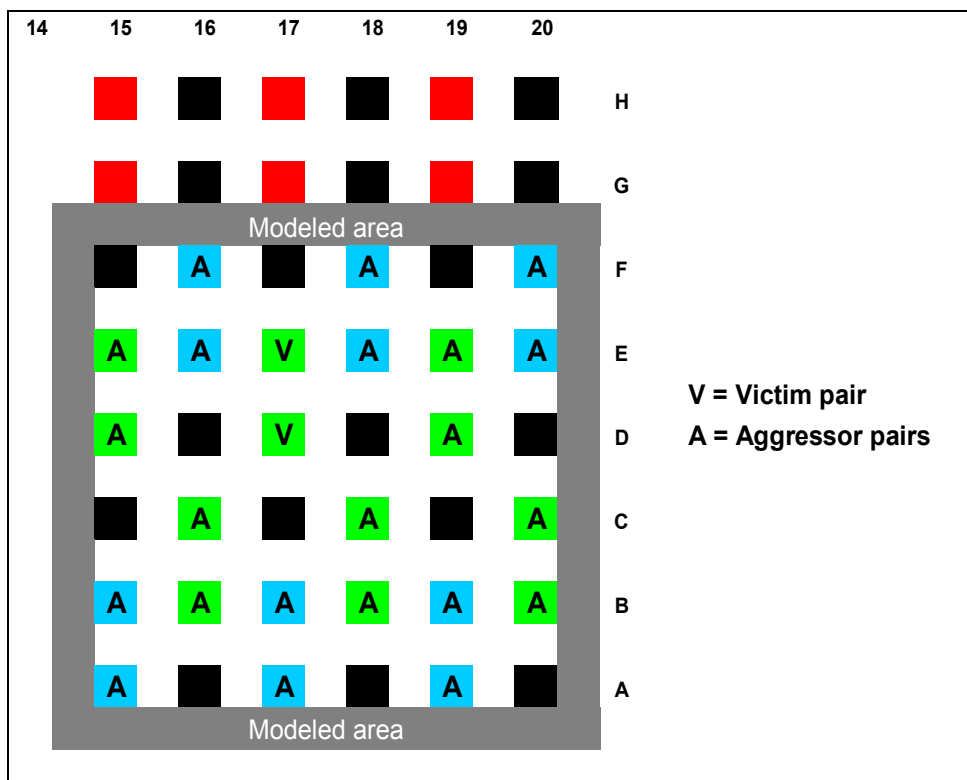

Figure 2 – RapidIO SE Array™ connector to Final Inch® Test Board Mapping

Procedure

Interconnect Budget

The interconnect budget can be best illustrated by the mask shown in Figure 3. In order to pass the RapidIO constraints for loss and jitter, the simulated eye waveform must not touch any location within the grey areas shown. Calculated interconnect budget values are shown in Table 3.

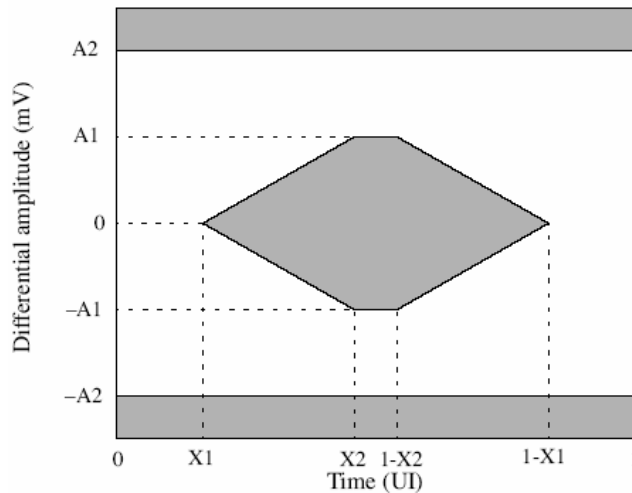

Figure 3 - Example mask template

Interval (See Fig. 3)	Near-end value	Far-end value	Units
X1 to 1-X1	260	140	psec
X2 to 1-X2	88	64	psec
A1 to -A1	500	175	mV _{p-p}
A2 to -A2	1000	1600	mV _{p-p}

Table 1 – RapidIO Short Run Driver template intervals at 2.5 Gb/s

Interval (See Fig. 3)	Near-end value	Far-end value	Units
X1 to 1-X1	208	128	psec
X2 to 1-X2	70.4	51.2	psec
A1 to -A1	500	175	mV _{p-p}
A2 to -A2	1000	1600	mV _{p-p}

Table 2 – RapidIO Short Run Driver template intervals at 3.125 Gb/s

	Maximum Loss, A1 to -A1, Both Frequencies ($V_{DIFFp-p}$)	Minimum Eye Width, 2.5Gb/ps X1 to 1-X1	Minimum Eye Width, 3.125 Gb/ps X1 to 1-X1
Driver at Package Pin	0.500	0.65UI	0.65UI
Receiver at Package Pin	0.175	0.35UI	0.40UI
Interconnect budget:	0.350	0.3UI	0.25UI
	9.12 dB loss ¹	120ps	80ps

Table 3 - RapidIO short run interconnect budget max loss and min eye width calculated values

¹The worst case operational loss budget at 1.25 GHz Nyquist frequency is calculated by taking the minimum input voltage to the receiver ($V_{RX-DIFF} = 175$ mV) divided by the minimum driver output voltage ($V_{TX-DIFF} = 500$ mV). $175/500 = .35$, which after conversion results in a maximum loss budget of 9.12 dB.

Transmitter Compliance Measurements

Setup for Tj for UI Measurements

As mentioned in the previous section, the driver stimulus' jitter was adjusted until the transmitter exhibited the maximum total jitter allowed by the RapidIO specification at the driver package pins under the compliance load shown in Figure 4 below. The RapidIO specification does not specify the range of capacitor values allowed for the AC coupling capacitors. We set C to 100nF for all simulations because it is a popular value in the industry. Table 4 shows the resulting output measurements.

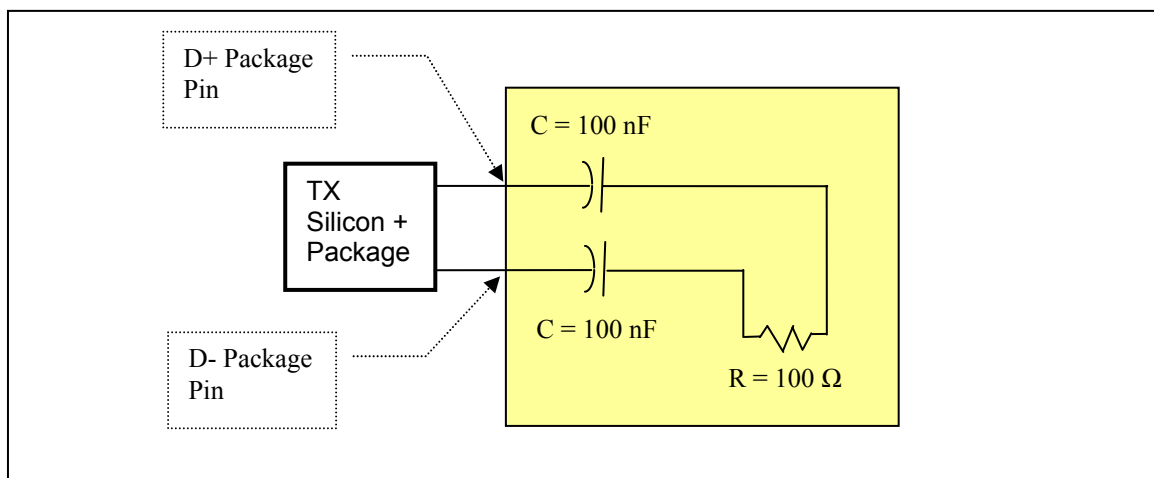

Figure 4 - RapidIO Compliance Test/Measurement load



	V_{p-p}	Total Jitter @ 2.5 Gb/s	Total Jitter @ 3.125 Gb/s
Specification	≥ 500 mV	≤ 140 psec	≤ 112 psec
Measured	500.0 mV	140.2 psec	111.9 psec

Table 4 - RapidIO TX Silicon + Package Measurements at Package Pin

The eye pattern generated in the RapidIO driver compliance test simulations can be found in [Appendix A](#) of this paper, pictures #1 and #3.

Full Circuit Compliance Measurements

Differential Voltage and Eye Width Measurements at Receiver End

2.5 Gb/s Data Rate

SEAM/SEAF Connector, 7 mm Stack Height	Max RX Jitter at UI = 400 psec	Min RX Eye Width, X1 to 1-X1 (See example mask template)	Min RX Differential Voltage, A1 to -A1 ¹ (See example mask template)	Pass/Fail
Specification	≤ 260 psec	≥ 140 psec	≥ 175 mV _{p-p}	-
10" total trace ²	141.7	387.3	347.4	Pass
20" total trace	161.6	354.4	240.2	Pass
22" total trace	161.5	348.3	229.8	Pass
24" total trace	178.5	334.7	217.4	Pass
26" total trace	177.2	330.6	204.4	Pass
28" total trace	181.3	324.3	193.4	Pass
29" total trace	185.4	318	173.8	Fail

Table 5 - RapidIO Measurements at Receiver End, 2.5 Gb/s data rate

¹X2 to 1-X2, the mid bit sample time, is 64 ps when UI = 400 psec.

²The total trace length specified is the sum of the two differential trace lengths in the SEAM/SEAF test fixture model, as shown in Figure 1. These traces are always kept equal in length in each simulation.

The 2.5 Gb/s eye pattern generated in the RapidIO circuit simulation with 28 inches total trace length can be found in [Appendix A](#) of this paper, picture #2.

3.125 Gb/s Data Rate

Instead of starting from scratch, we'll start the 3.125 Gb/s simulations based on the insertion loss of the circuit with 28 inches of trace. The insertion loss of the RapidIO circuit with various trace lengths is shown in Figure 4. At the Nyquist frequency for the 2.5 Gb/s data rate (1.25 Gb/s), the insertion loss of the circuit with 28 inches total trace

length is -8.82 dB. Moving over to the Nyquist frequency for 3.125 Gb/s data rate (1.5625 Gb/s) shows that the insertion loss for the circuit with 23 inches of total trace length is also -8.82 dB, so 22 inches of trace is a safe place to start the 3.125 Gb/s RapidIO simulations.

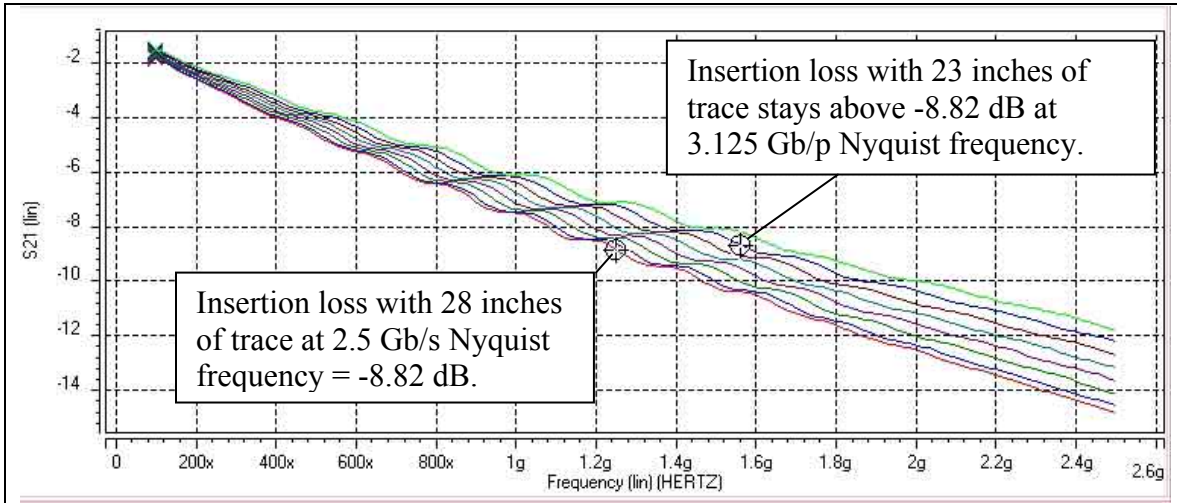

Figure 5 - RapidIO circuit insertion loss at trace lengths between 28 inches and 35 inches

SEAM/SEAF Connector, 7 mm Stack Height	Max RX Jitter at UI = 320 psec	Min RX Eye Width, X1 to 1-X1 (See example mask template)	Min Rx Differential Voltage, A1 to -A1 ¹ (See example mask template)	Pass/Fail
Specification	≤ 192 psec	≥ 128 psec	≥ 175mV _{p-p}	-
22" total trace	157.5	256.6	190.4	Pass
23" total trace	163.9	251.0	165.3	Fail

Table 6 - RapidIO Measurements at Receiver End, 3.125 Gb/s data rate

¹X2 to 1-X2, the mid bit sample time, is 51.2 psec when UI = 320 psec.

²The total trace length specified is the sum of the two differential trace lengths in the SEAM/SEAF Series test fixture model, as shown in Figure 1. These traces are always kept equal in length in each simulation.

The 3.125 Gb/s eye pattern generated in the RapidIO circuit simulation with 33 inches total trace length can be found in [Appendix A](#) of this paper, picture #4.



Conclusions

A single Samtec SE Array™ SEAM/SEAF Series 7mm stack height connector in a board-to-board configuration can be used in RapidIO systems with total trace lengths not to exceed 28 inches at 2.5 Gb/s data rates, or 22 inches at 3.125 Gb/s data rates, when used with Samtec's Final Inch® routing, breakout, and trace width solutions. Because loss is the dominant contributor to system degradation, designers should be aware that using smaller trace widths, laminates with higher loss tangent, and sub optimal routing solutions with higher pair-to-pair coupling and additional via stubs will decrease overall performance and the maximum allowable trace length. It is advisable when designing systems that approach the maximum jitter limits to perform detailed modeling, simulation, and measurement of the target design including the effects of material properties, traces, vias, and additional components.

Appendix A – Waveform images

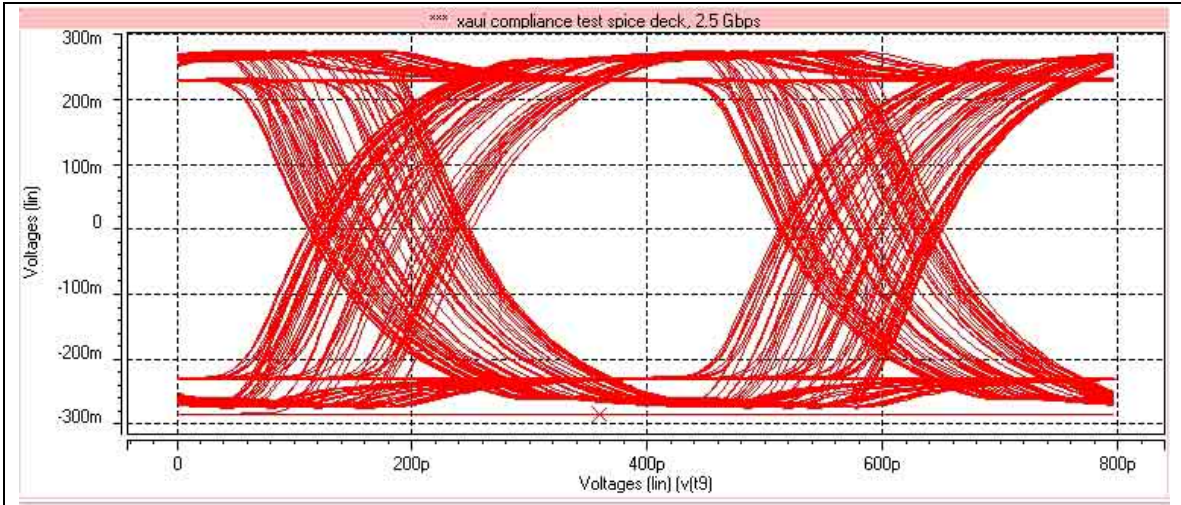

Picture 1 – Worst case stimulus eye waveform at 2.5 Gb/s, probed at Xilinx driver package pins, connected to compliance test/measurement load

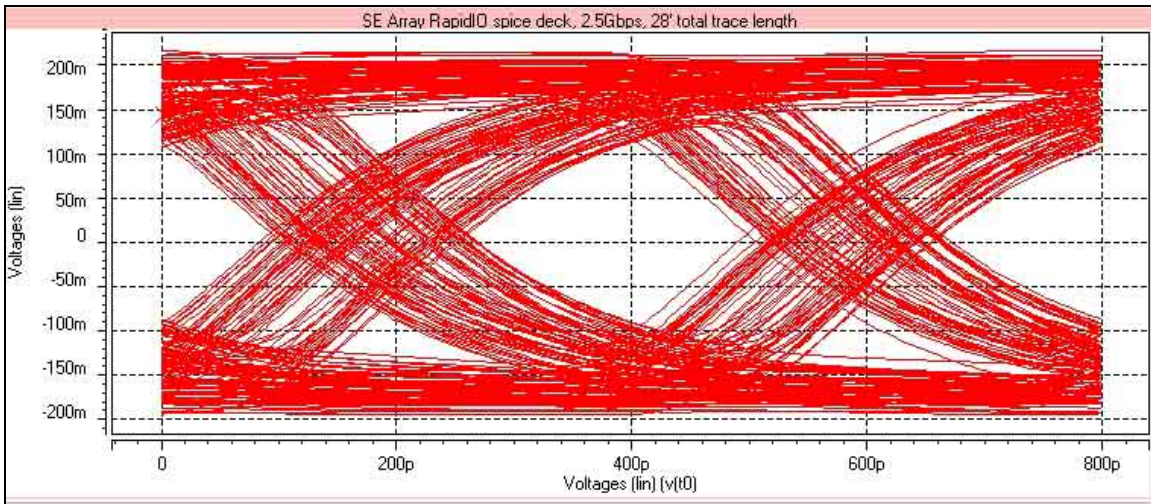

Picture 2 – RapidIO circuit eye waveform at 2.5 Gb/s, probed at terminator pins, 28 inches total trace length

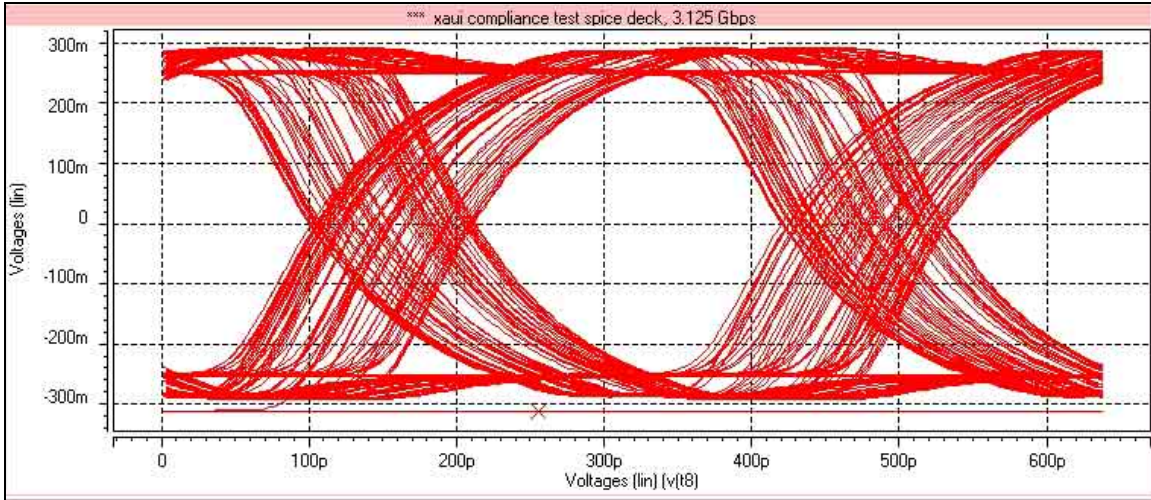

Picture 3 – Worst case stimulus eye waveform at 3.125 Gb/s, probed at Xilinx driver package pins, connected to compliance test/measurement load

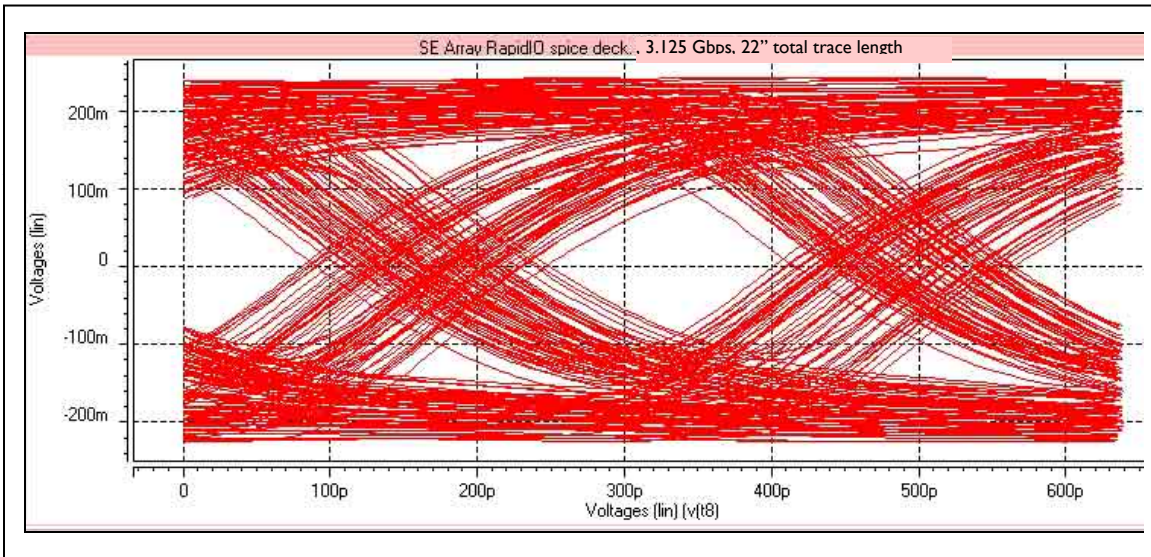

Picture 4 – RapidIO circuit eye waveform at 3.125 Gb/s, probed at terminator pins, 22 inches total trace length