



How to use Connector Spice Models

Scott McMorrow
Teraspeed Consulting Group LLC

***Audio Information for
today's presentation***

- Dial: 1-800-944-8766 (US)
- Dial: 1-317-713-0002 (Outside the US)
- Use Conference Code 31648



**TERASPEED
CONSULTING
GROUP**

Outline



- **Not-so-basic theory**
 - “Simple” 2-line models
 - Capacitance model
 - Inductance model
 - Loop vs. partial inductance
 - Classical cascaded model
 - Problem with circuit connections and ground
 - Tee model
 - Transmission line model transformation
 - M Line models
 - Probing
 - Simulation examples

"Simple" 2-line Model

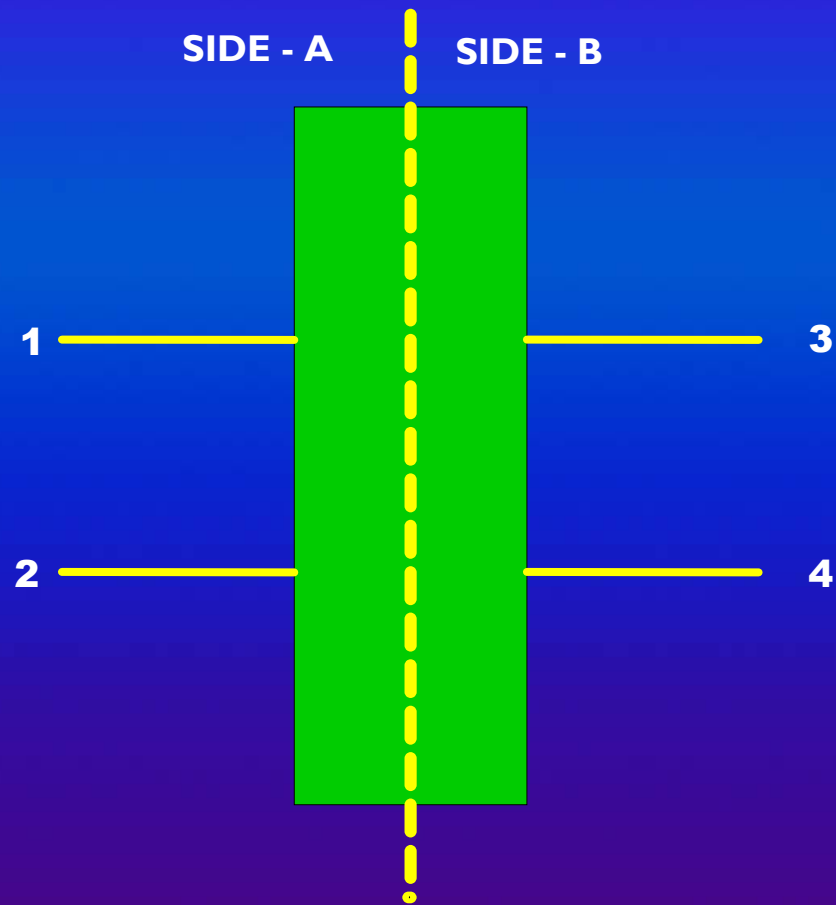

TERASPEED
CONSULTING
GROUP

"Simple" 2-line Capacitance Model

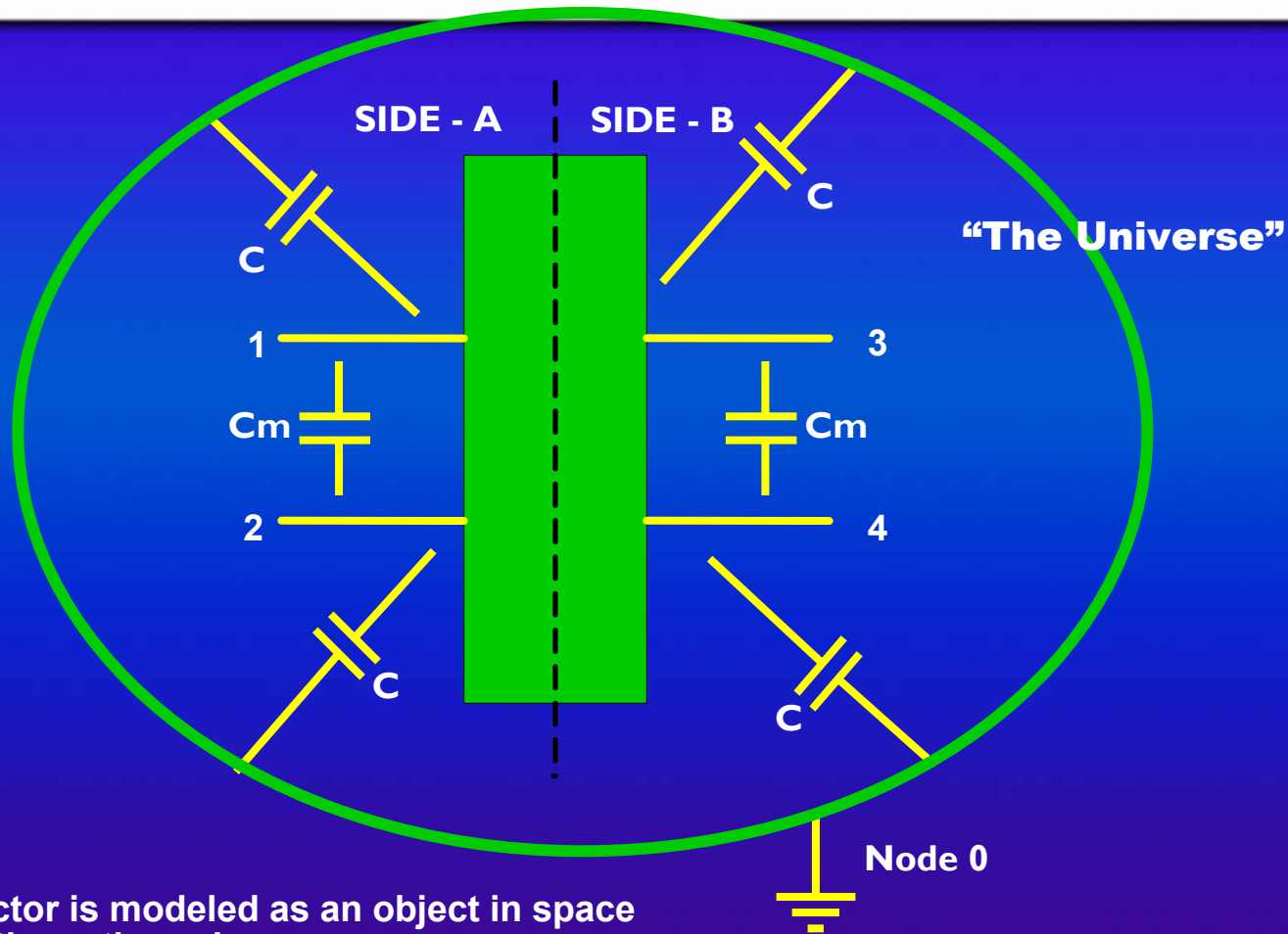

A mated connector is modeled as an object in space surrounded by the entire universe.

"The Universe", also known as SPICE Node 0, is used for calculation of self-capacitance (C).

Mutual capacitance (C_m), is calculated between metal objects.

Capacitance Summary



- **Self capacitance is defined to be the capacitance of a metallic object to all other objects in the universe (universal ground).**
 - SPICE node 0 is another name for the universal ground.
- **Mutual capacitance is defined to be the capacitance between any two metallic objects.**
- **For the capacitance calculation of a circuit to be correct for multi-line systems, the self and mutual capacitance must be included, and undisturbed by the circuit.**

"Simple" 2-line Loop Inductance Model

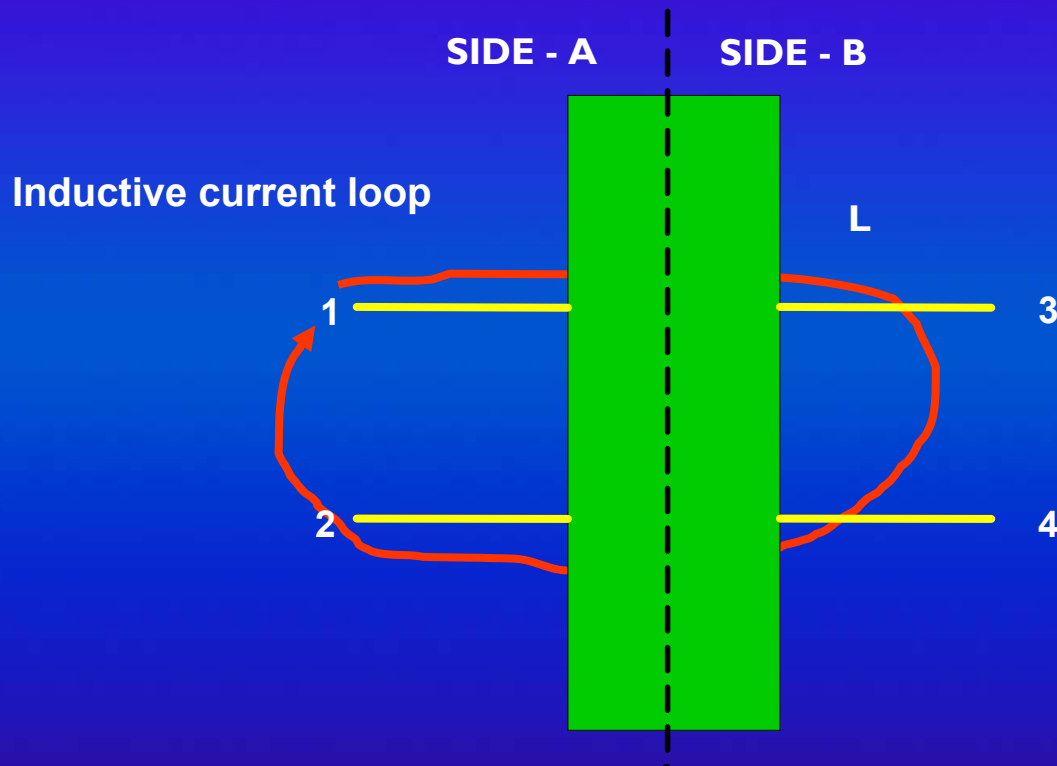

Inductance is valid only when an entire loop is traversed. In this case, a 2-line system, loop inductance is calculated across the above path.

"Simple" 2-line Partial Inductance Model



Partial Inductance Loop

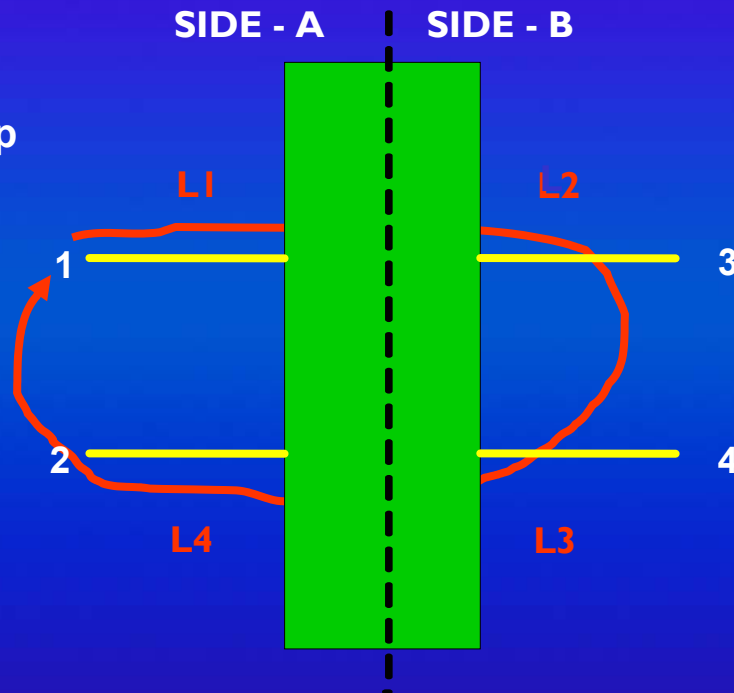

Mathematically, the full inductance loop can be broken into partial inductances.

However, $L \neq L1 + L2 + L3 + L4$.

"Simple" 2-line Partial Inductance Model with Mutual Inductance

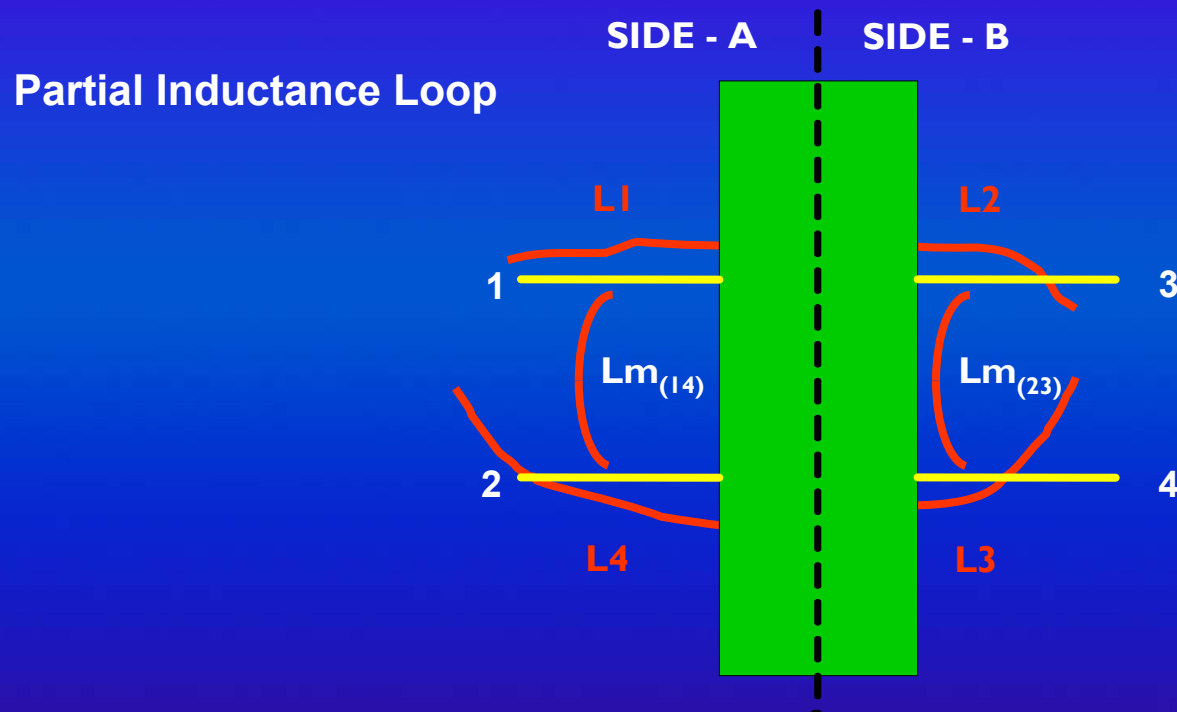

Mathematically, the full inductance loop can be broken into partial inductances.

$$L = L1 - Lm_{(14)} + L2 - Lm_{(23)} + L3 - Lm_{(32)} + L4 - Lm_{(41)}$$

Mutual inductance (Lm) between elements completes the loop.



TERASPEED
CONSULTING
GROUP

Inductance Summary



- **Loop inductance is the only thing that can be measured.**
 - Requires a closed path.
- **Mathematically, the loop can be broken apart into partial inductances.**
 - Partial inductance is only valid when combined into a total loop, and the mutual inductances are also included.
 - If mutual inductance is not included, a loop inductance calculation, or simulation, is incorrect.



"Simple" Infinite 2-line Model

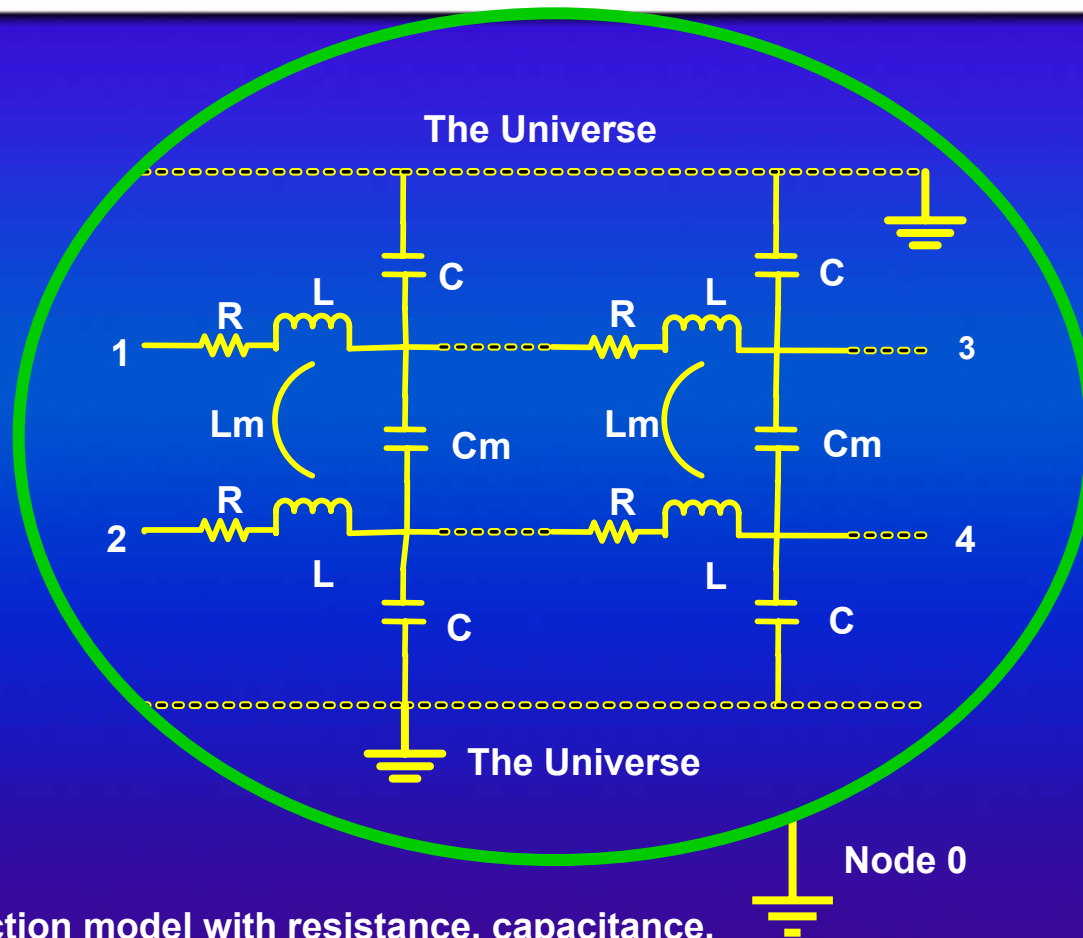

Cascaded multi-section model with resistance, capacitance, and partial inductances.

This model is valid for an infinitely long line, or an infinite number of sections, but will have issues when connected to a circuit with ground.



TERASPEED
CONSULTING
GROUP

"Simple" 2-line Model with Circuit Connections

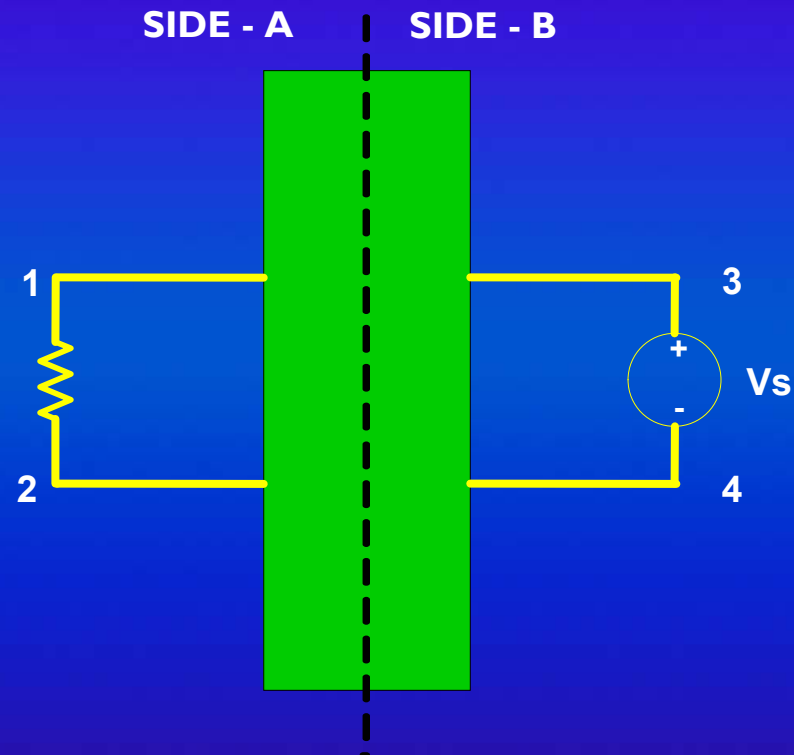

Circuit connections are valid and all KCL equations can be solved, but, how are absolute voltage values referenced?

SPICE requires that there be at least one ground node (Node 0) in the circuit.

"Simple" 2-line Model with Circuit Connections and Ground

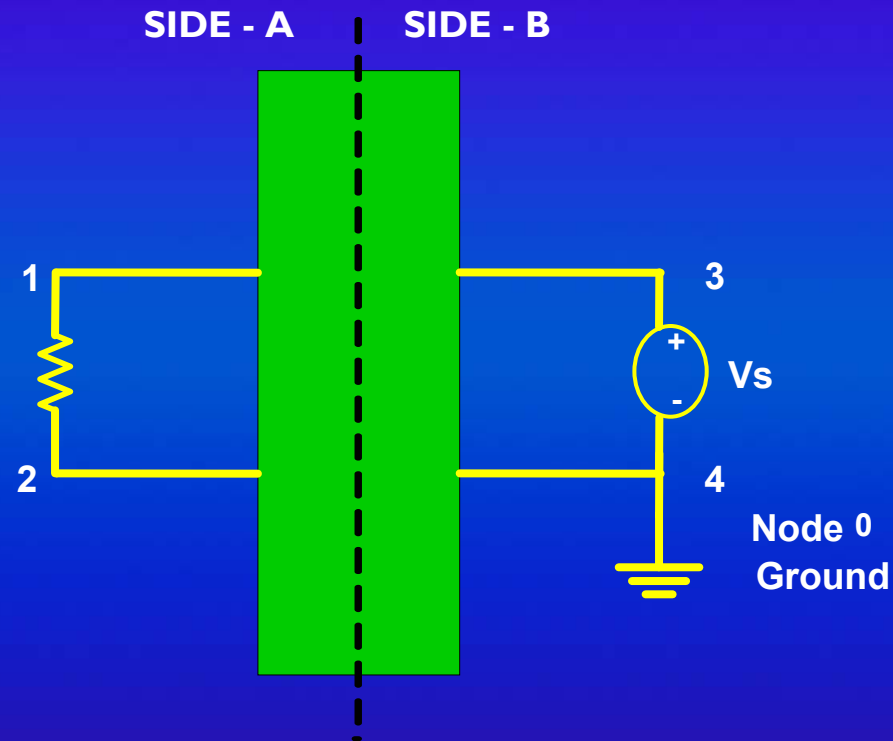

Circuit has been modified to include a ground node as an absolute voltage reference for SPICE.

Notice that nodes 1 and 2 "float" through the connector.



TERASPEED
CONSULTING
GROUP

"Simple" 2-line Model with Circuit Connections and Ground

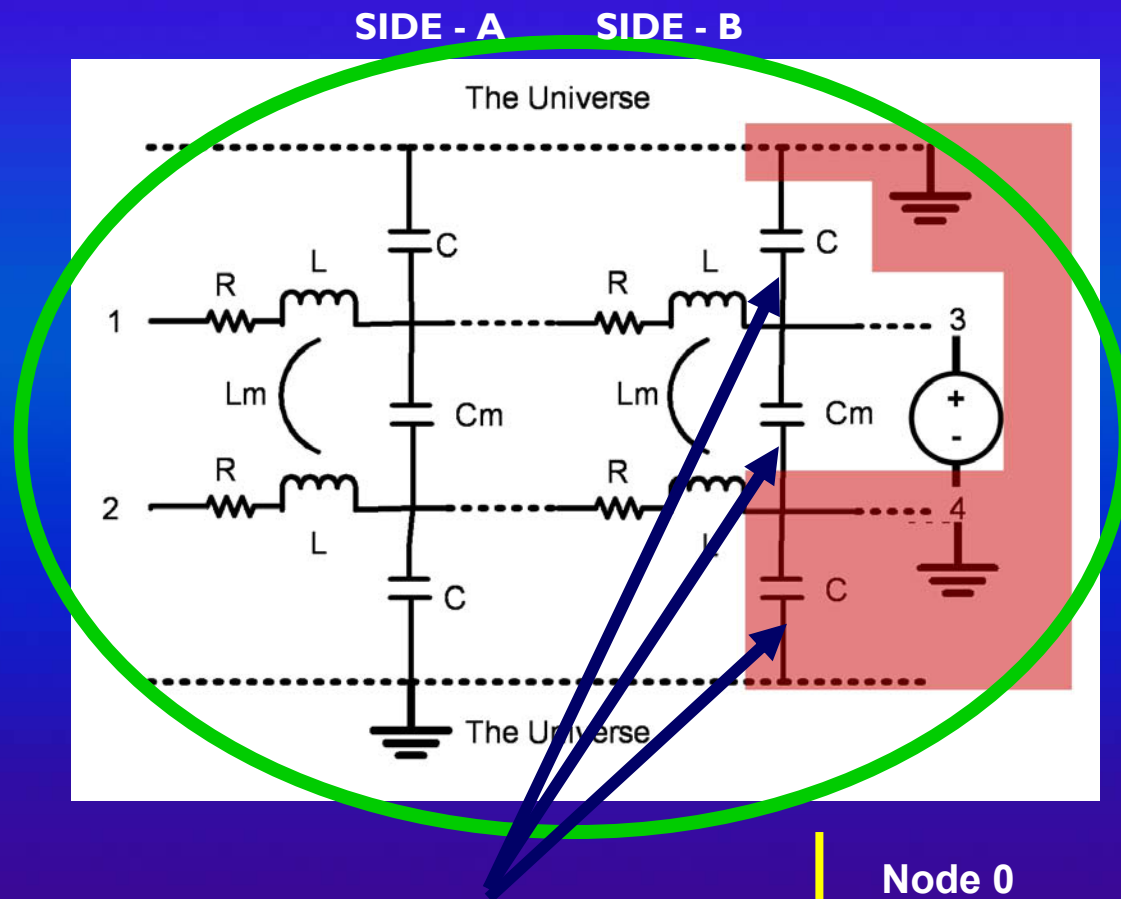

**What is the problem with this circuit model?
Notice that some of the capacitors are shorted out.
Improper circuit connections will result in invalid results.**



One Section of Tee Model

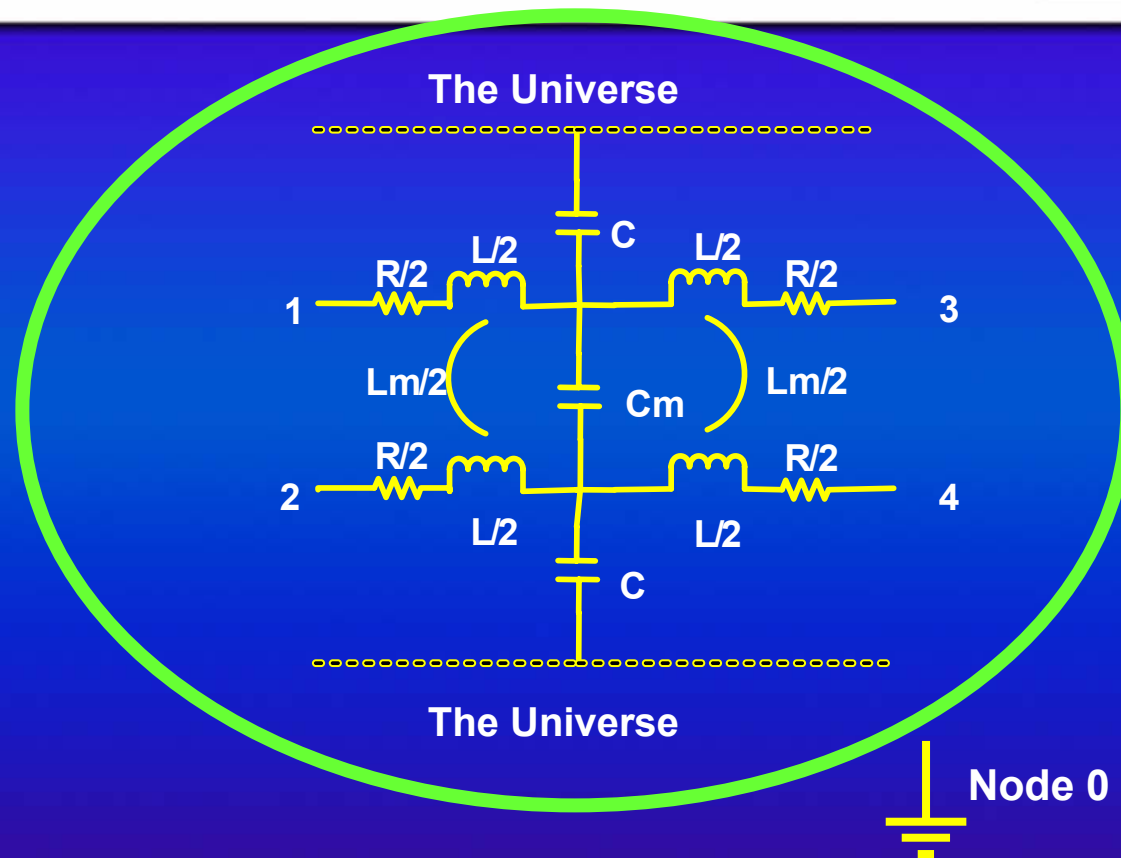

The solution is to isolate capacitances by splitting the resistance and inductance on either side.

This also provides a symmetric model as a side benefit.

Some Samtec SPICE connector models utilize this Tee topology.



One Section of Tee Model with Circuit Connections and Ground

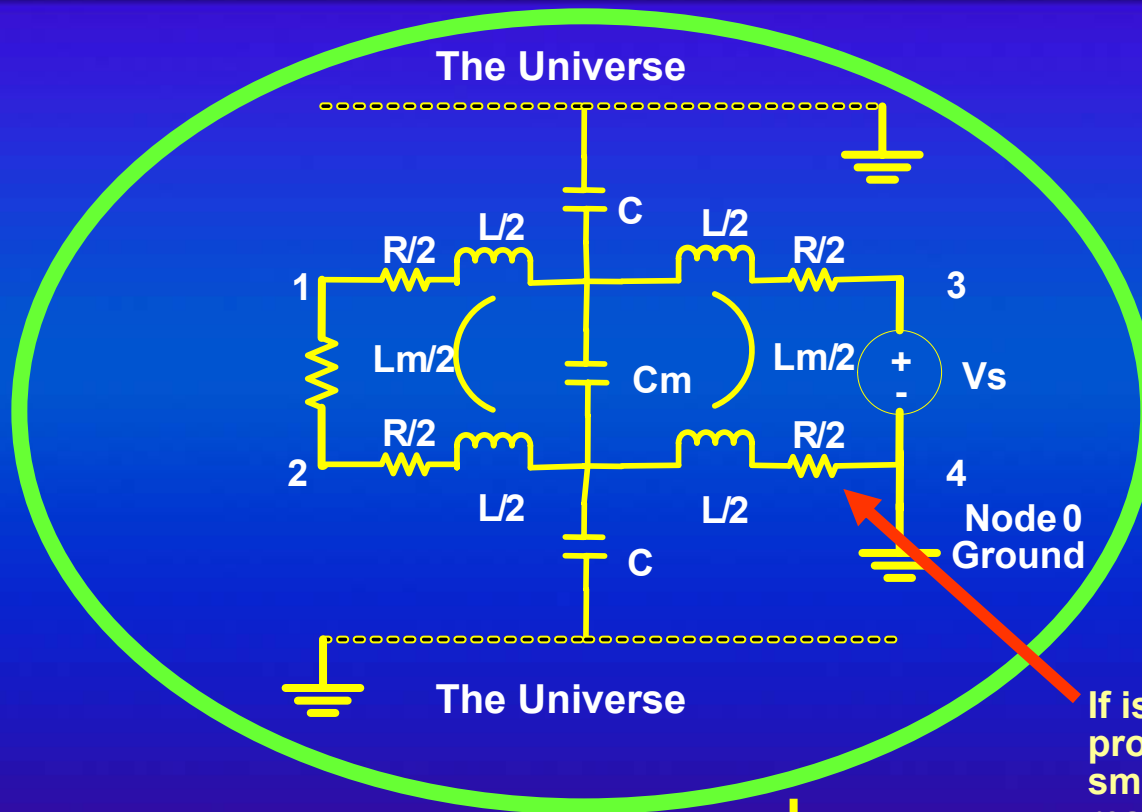

The solution is to isolate capacitances by splitting the resistance and inductance on either side, in a classic Tee, as some Samtec models do.

These model “sections” may be cascaded just like the standard RLC model section.

This also provides a user-friendly model which is symmetric as a side benefit.

If isolation is not provided in the model, small, 0.01 ohm resistors should be added externally.



TERASPEED
CONSULTING
GROUP

Ground Effect on Capacitance Summary



- **SPICE requires one universal ground in a circuit.**
 - Called 0, GND.
- **Standard RLC model cascades can be sensitive to the placement of Node 0.**
 - Ground can short out capacitors in the cascaded circuit.
- **A modified Tee topology can be used in modeling to solve the SPICE ground problem.**
 - This model can be cascaded and is symmetric.
- **In lieu of a modified Tee topology, small isolation resistors can be added to the external circuit.**



"Simple" 2-line Model with Grounds on Both Sides

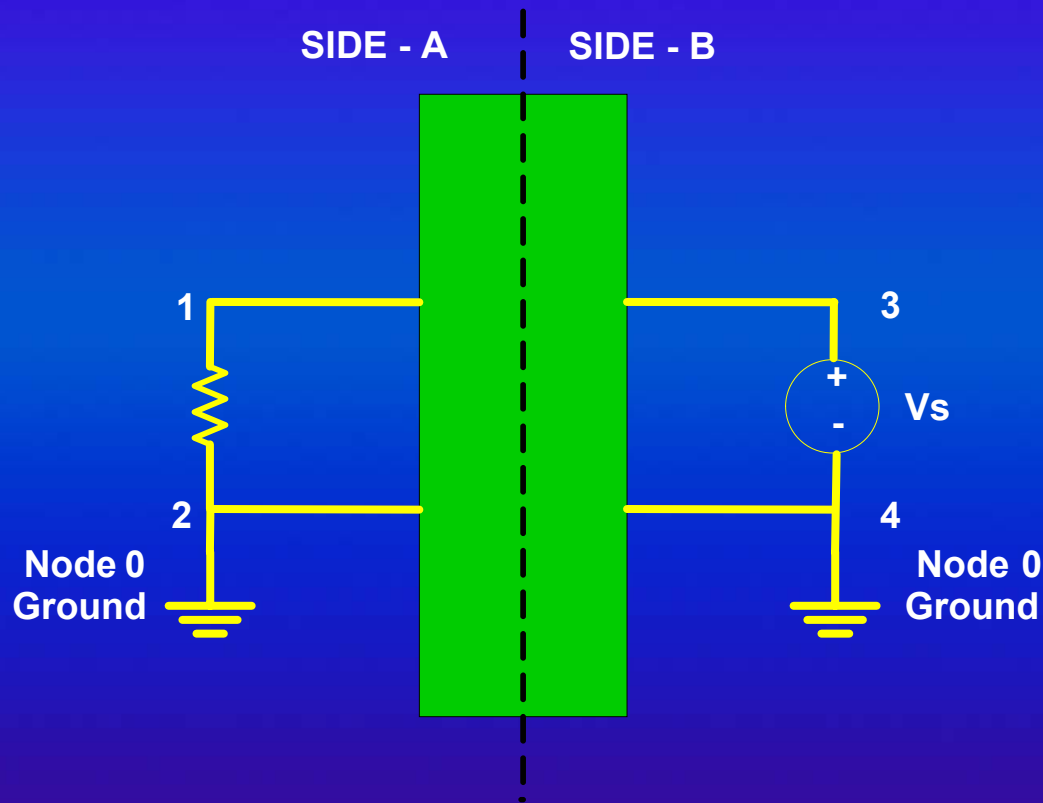

What happens if both sides of connector are tied to ground?

One Section of Tee Model with Grounds on Both Sides

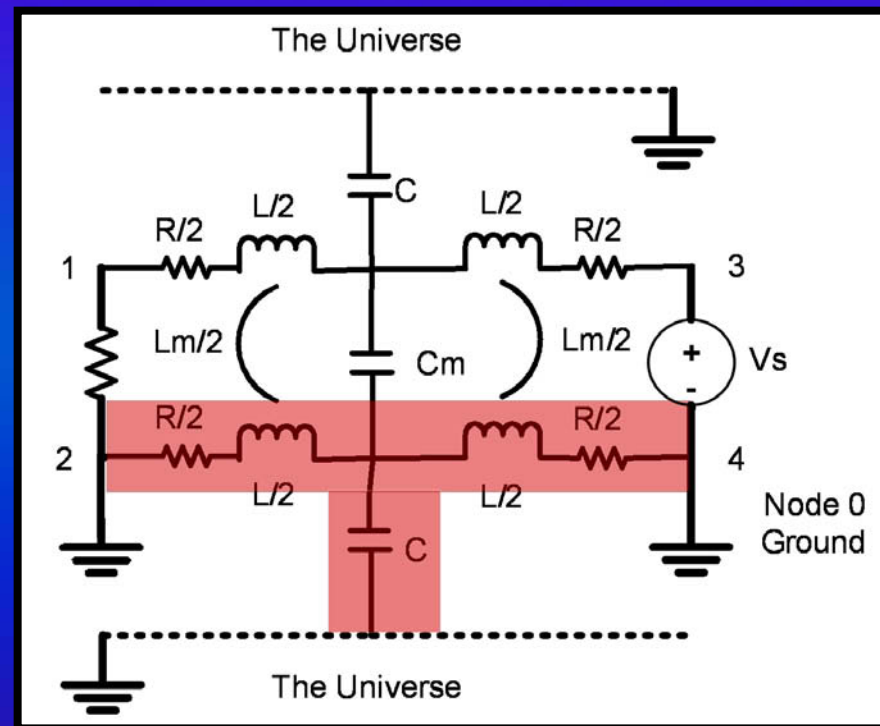

When both sides of the circuit are grounded, inductors and resistors in the ground path are shorted out.
Net current flow between nodes 2 and 4 is zero.

Multiple Ground Summary



- **Multiple circuit grounds can have unintended side effects on circuit inductance.**
 - Shorts across inductors invalidate the loop inductance of the circuit.
- **Important!**
 - Place node 0 ground on one side of a connector to avoid the potential of shorting out circuit elements.

Transformation of Tee to Transmission Line Equivalent

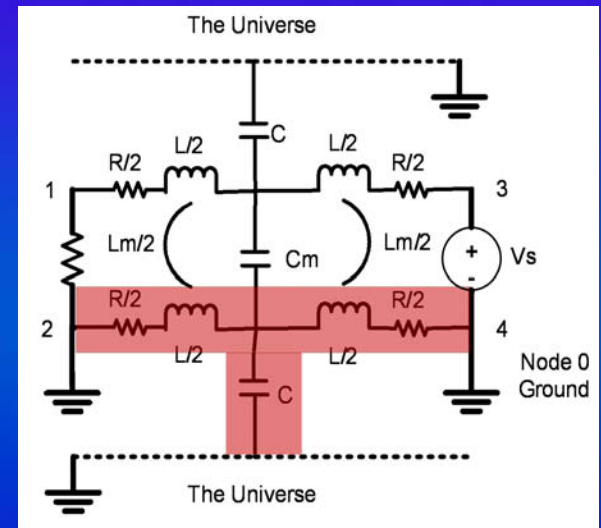
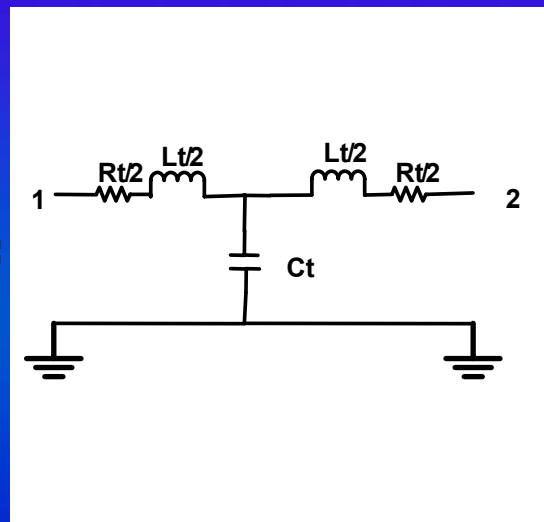
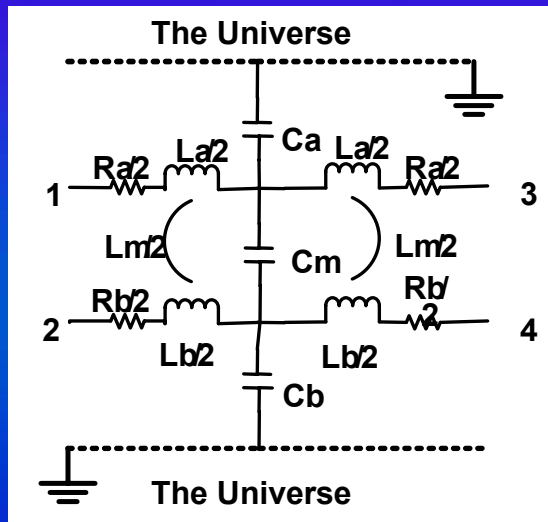

If one line is defined to be “return path”, a M-line model can be transformed into an (M-1)-line transmission line model.

Our 2-line model then becomes a 1-line model (i.e. – a single-ended transmission line.)

Information is lost in this transformation! All ground and signal effects are lumped into the signal path. We no longer have separate visibility of signals and ground.

$$R_t = R_a + R_b$$

$$L_t = L_a + L_b - 2 L_m$$

$$C_t = C_a + C_b + 2 C_m$$

4-Line SPICE Connector Model

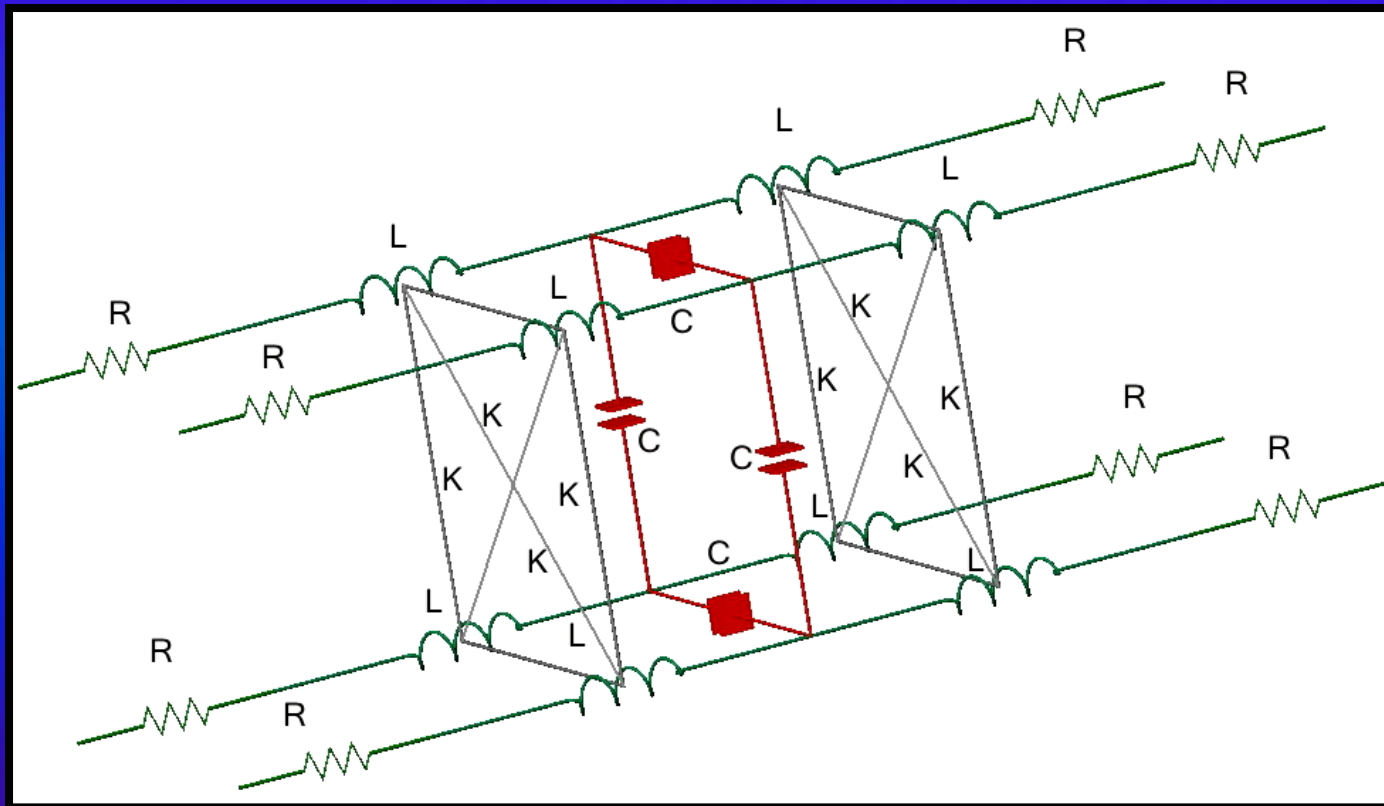

4-line Spice Model w/o Self Capacitance shown

1-Line SPICE Connector Model



```
** THIS SUBCIRCUIT IS **  
** FOR THE INTERNAL **  
** PINS OF THE QTH/QSH**  
** CONNECTOR **
```

```
*****IN*OUT*REF  
.SUBCKT QTH1QSI 1 2 3
```

```
L4 1 4 1.42NH  
C5 4 3 1.25PF  
L5 4 2 1.42NH  
.ENDS QTH1QSI  
** END OF INTERNAL PIN SUBCIRCUIT **
```

Single Tee-section LCL SPICE Model

```
** THIS SUBCIRCUIT IS **  
** FOR THE INTERNAL **  
** PINS OF THE QTH/QSH**  
** MATED CONNECTOR **
```

```
*****IN*OUT*REF  
.SUBCKT QTH1QSIL 1 2 3
```

```
T4 1 3 2 3 Z0=47.61 TD=59.51PS  
.ENDS QTH1QSL  
** END OF INTERNAL PIN T-LINE SUBCIRCUIT **
```

Single Transmission Line SPICE Model

Samtec single-line models utilize the multi-line to transmission line transformation to produce valid models.

This transformation assumes that all other pins on the connector are configured as ground return paths.

Both the LCL and the T-line model are equivalent. However, the T-line model has better fidelity in simulation, over the broadest bandwidth, because a transmission line model is fully distributed.



TERASPEED
CONSULTING
GROUP

M-Line SPICE Model Summary



- **All 2-line considerations apply to M-lines as well.**
- **SPICE connector models having M-lines are appropriate for combined signal, return path, and power/ground simulations.**
 - Only one side of the connector should contain Node 0 grounds.
 - If there are multiple dedicated ground pins AND those pins are attached to a low impedance plane, it may be appropriate to connect all pins on a side together.
 - SPICE models with Tee topology sections can have multiple pins shorted without loss of accuracy.
 - But ... do not, under any circumstances, connect a Node 0 ground to both sides of a connector. All remaining “ground” connections should float relative to the connector.
- **Samtec Final Inch® simulation models are pre-configured with correct grounding across the entire design.**



Single-Node SPICE Probes

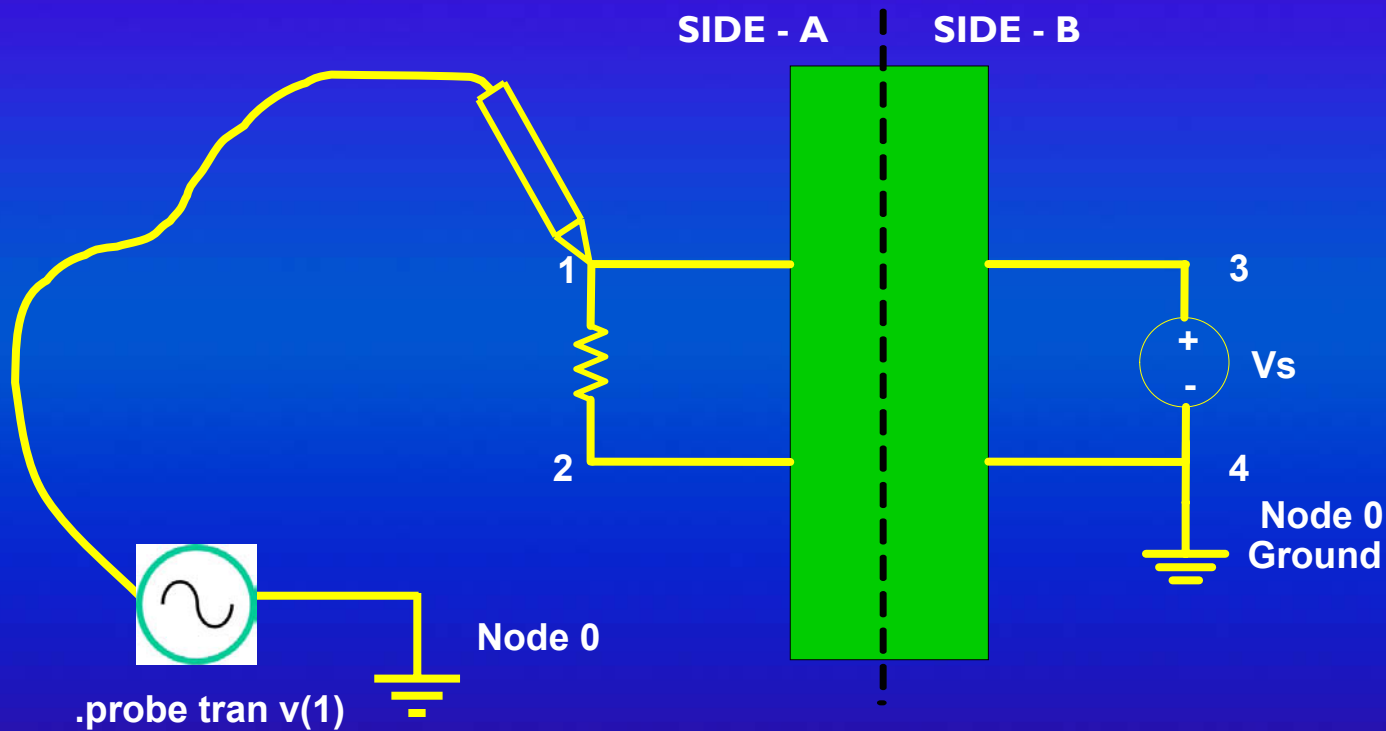

Single-node SPICE measurements are always relative to node 0.
Noise in return path (2-3) across connector is included in measurement.

Two-Node SPICE Probe Equivalent to Single-Node Probe

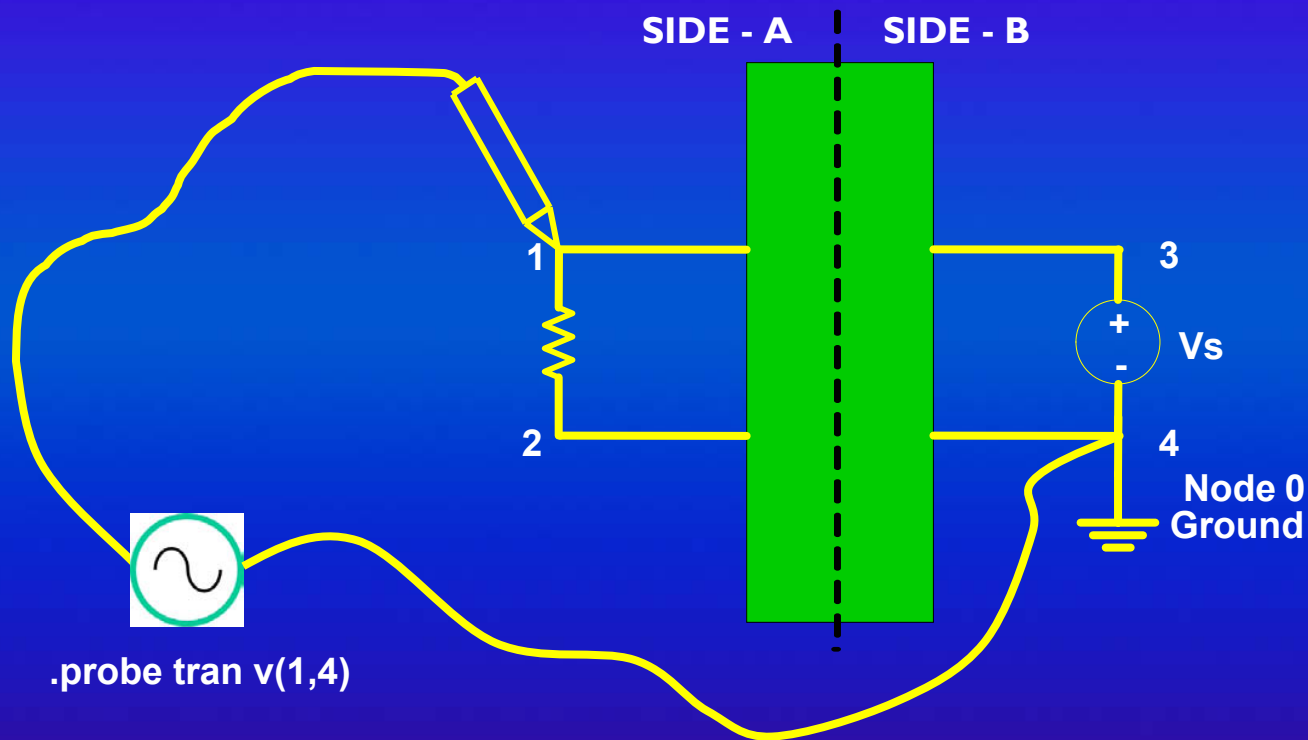

Two-node SPICE measurements allow flexibility in choosing the appropriate signal return point.

In this case, we have chosen a ground probe placement equivalent to the previous slide. The result will be the same.

Correct Two-Node SPICE Probe

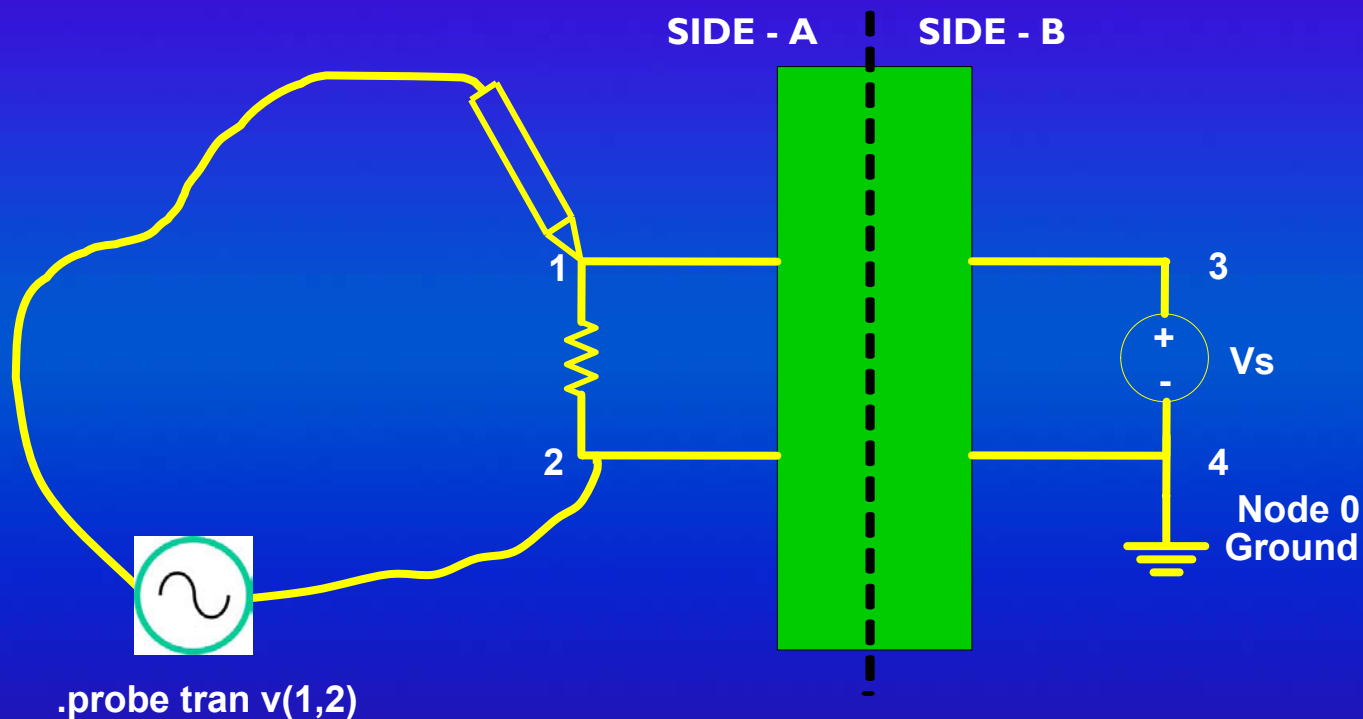

Two-node SPICE measurements allow flexibility in choosing the appropriate signal return point.

This is the correct method for measuring signals.

Single-Node SPICE Probe with VCVS

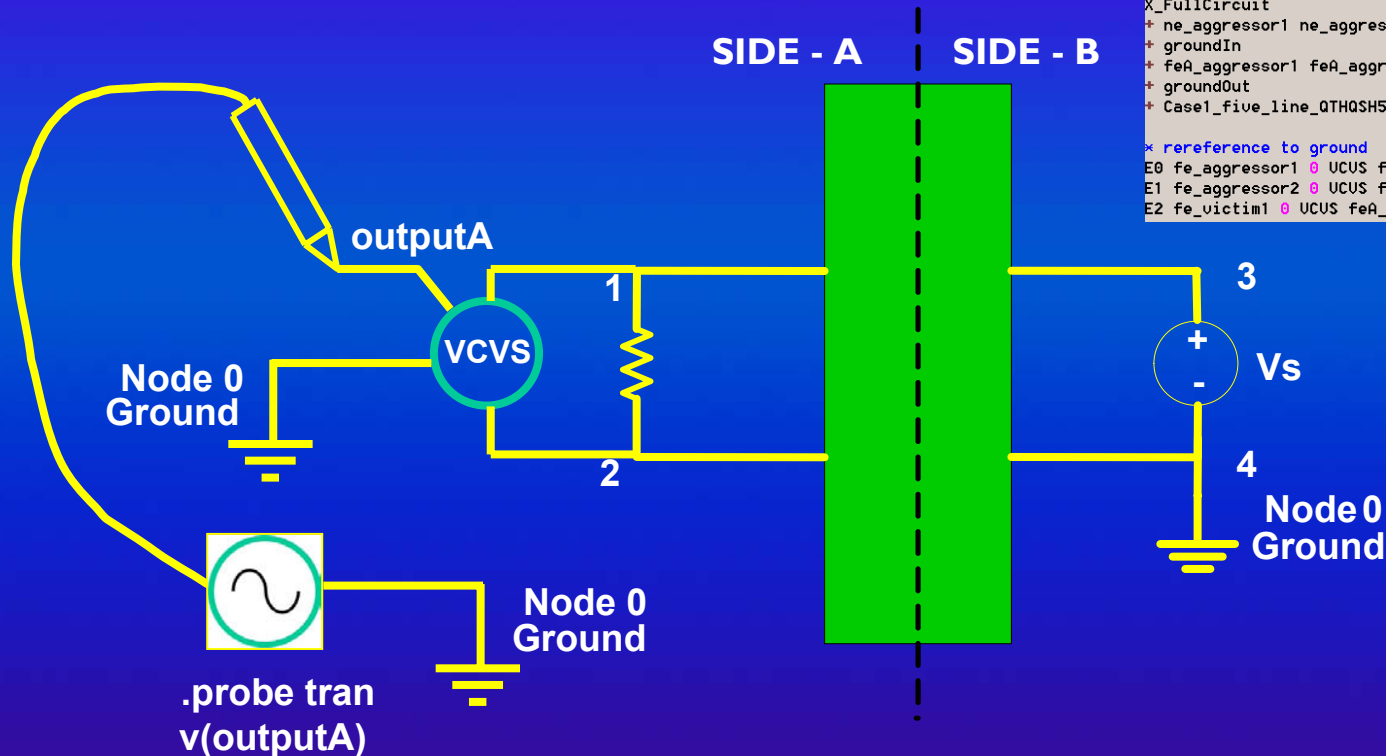

```
* Output waveforms
.probe U(ne_gressor1) U(fe_gressor1)
.probe U(ne_victim1) U(fe_victim1)

X_FullCircuit
+ ne_gressor1 ne_gressor2 ne_victim1 ne_gressor3 ne_gressor4
+ groundIn
+ feA_gressor1 feA_gressor2 feA_victim1 feA_gressor3 feA_gressor4
+ groundOut
+ Case1_five_line_QTHQSH5mmSmaTraceBreakoutConnectorBreakoutTraceSma_FI

* rereference to ground
E0 fe_gressor1 0 UCUS feA_gressor1 groundOut 1
E1 fe_gressor2 0 UCUS feA_gressor2 groundOut 1
E2 fe_victim1 0 UCUS feA_victim1 groundOut 1
```

A VCVS may be used to simplify probing with single-node probes and meaningful node names.

Samtec Final Inch® SPICE models use this method to avoid improper measurement choices by the user.



TERASPEED
CONSULTING
GROUP

SPICE Probe Summary



- **Single-node SPICE probes are always referenced to Node 0 ground.**
- **Two-Node Probes provide flexibility in choosing the signal return node.**
 - A low impedance signal return node (“local ground”) closest to the signal node should always be used.
- **A VCVS may be used to simplify probing with single-node probes and meaningful node names.**
 - Samtec Final Inch[®] simulation models use the VCVS method to help users avoid measurement error.

Test Circuit with HSEC8 Connector

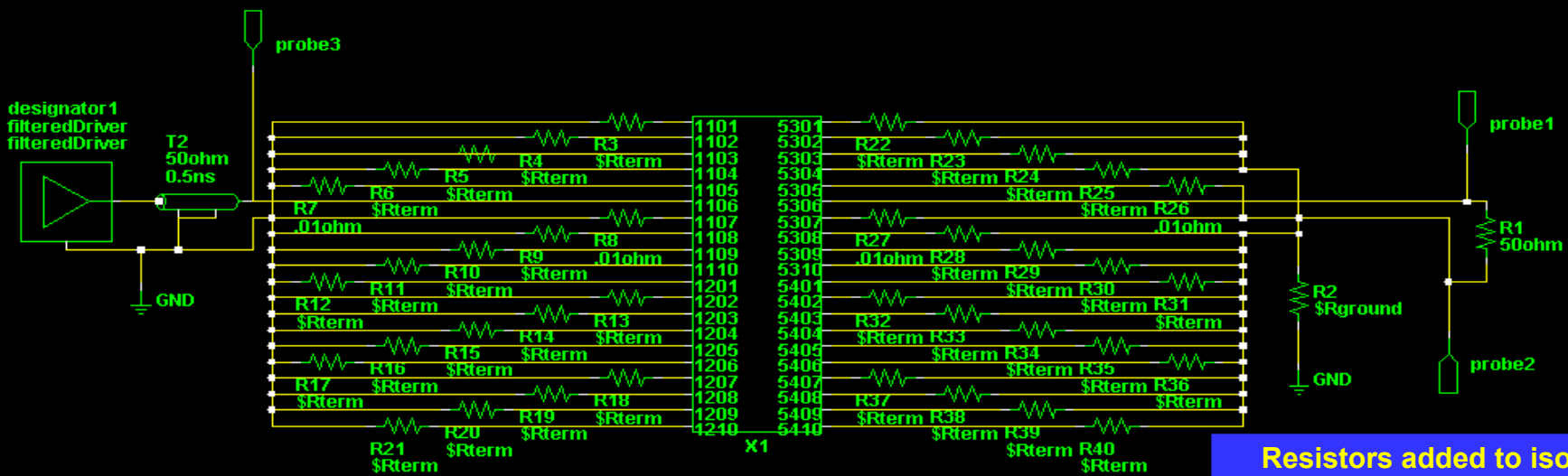

Resistors added to isolate capacitors connected to pins.
 0.01 ohm resistors used for ground connections.
 50 ohm resistors used for unconnected signals.
 No resistors necessary when transmission line connections are used.

HSEC8 with one signal driven, one ground, and all other pins terminated.
 Rground – 1 MOhm for floating ground, 0.01 Ohm for Node 0 ground.
 Rterm = 50 ohm to local ground.
 Ground pins connected to local ground with 0.01 Ohm resistors to isolate pins.

Comparison of Node 0 vs. Floating Reference Across Connector

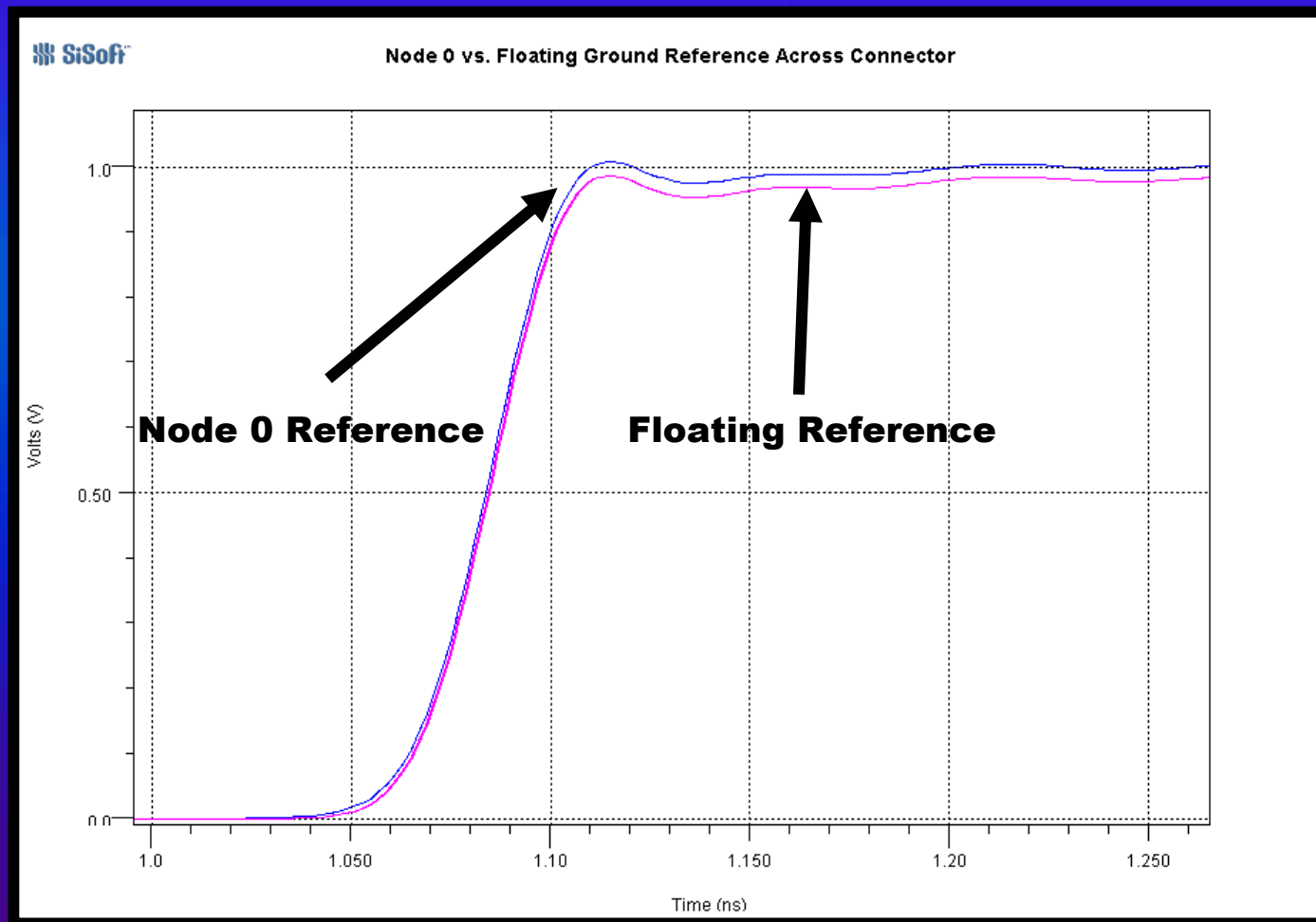

Comparison of Node 0 vs. Floating Ground Referenced Probe

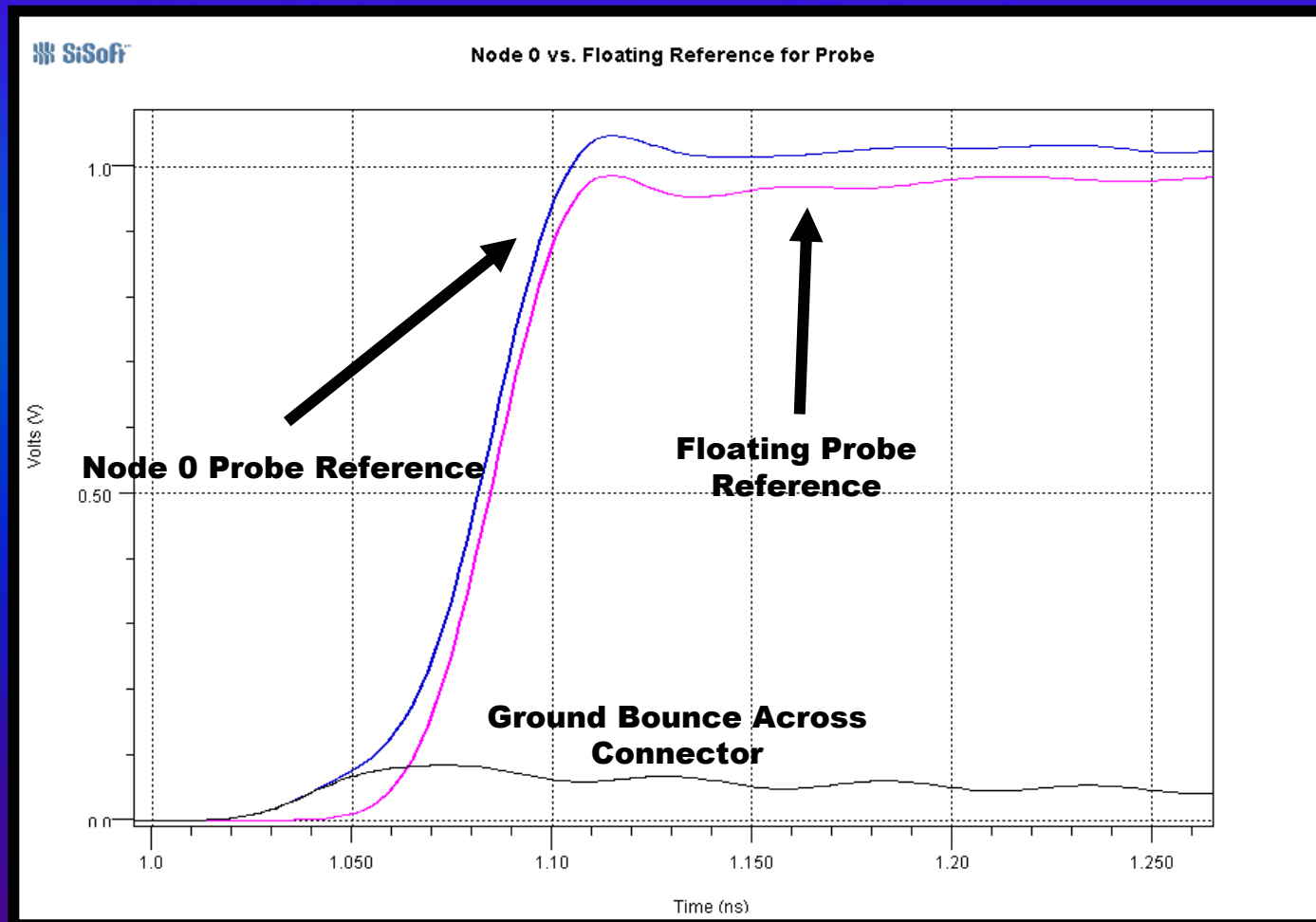

- **Three techniques to good SPICE simulations.**
 - Isolation resistors on all pins to avoid capacitor shorts.
 - Floating far side ground referencing.
 - Differential probing using floating ground reference.
 - Differential probing must always be used whenever floating far side ground referencing is used.



Final Summary



- **Accurate modeling and simulation of connectors requires:**
 - Isolation of the model from other elements using resistors.
 - Termination of unused signal pins.
 - Universal ground on one side and floating ground on the other.
 - Differential probing for accurate measurements.
- **Samtec Final Inch[®] simulation packages provide all the needed SPICE modeling to ensure successful end-to-end connector system modeling.**

In Closing



- For additional questions in regards to the information contained in today's presentation, please contact our Signal Integrity Group at: sig@samtec.com
- For a copy of today's presentation, please contact us at: ewebinar@samtec.com



TERASPEED
CONSULTING
GROUP



How to use Connector Spice Models

Scott McMorrow
Teraspeed Consulting Group LLC

***Audio Information for
today's presentation***

- Dial: 1-800-944-8766 (US)
- Dial: 1-317-713-0002 (Outside the US)
- Use Conference Code 31648



**TERASPEED
CONSULTING
GROUP**